

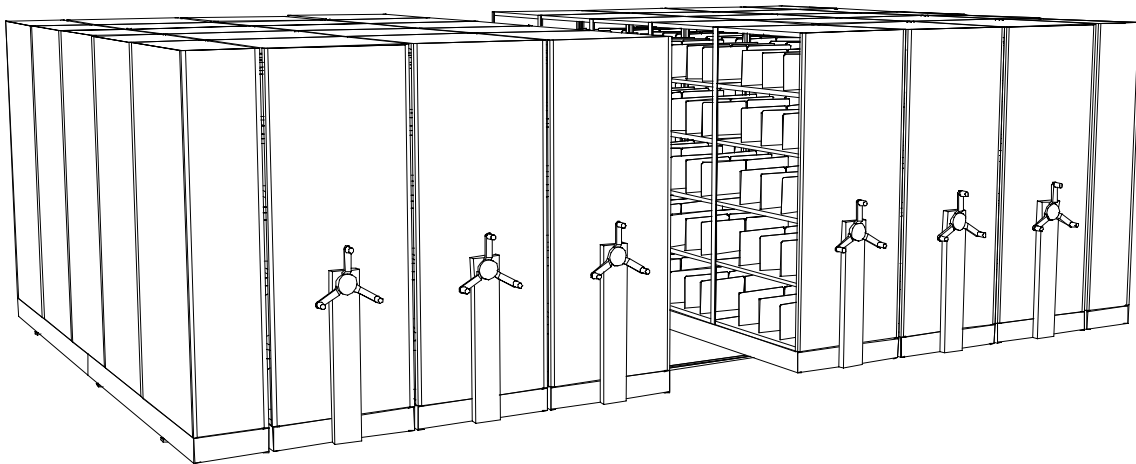

RICHARDS-WILCOX, INC.

A MEMBER OF THE **DEXION®** GROUP



Aurora Mobile Systems Basic Installation Manual



Aurora Mobile System
Basic Installation Manual

Richards Wilcox, Inc.
600 South Lake Street
Aurora, Illinois 60506
Phone 630 897-6951
Fax 630 897-6994

TABLE OF CONTENTS

INTRODUCTION	1
SYSTEM BENEFITS	1
PURPOSE OF MANUAL	1
GENERAL INFORMATION	2
SAFETY	2
WARRANTY	3
TOOLS AND MATERIALS	2
RAIL AND RAMP INSTALLATION	4
STATIC BASE INSTALLATION	18
STATIC BASE INSTALLATION INSTRUCTION	18
HAND-PUSH MOBILE BASE INSTALLATION	22
SYSTEMS LESS THAN 48" LONG WITH NO DECORATIVE END PANELS	23
SYSTEMS LONGER THAN 48" LONG WITH NO DECORATIVE END PANELS	23
ALL SYSTEMS WITH DECORATIVE END PANELS	23
MECHANICAL ASSIST MOBILE BASE INSTALLATION	26
LOW PROFILE (3750) INSTALLATION	26
UNITS <u>WITHOUT</u> DECORATIVE END PANELS	27
UNITS WITH DECORATIVE END PANELS	29
OFFICE 1000 (3100) AND INDUSTRIAL (1500) INSTALLATION	31
UNITS OVER 25 FT IN LENGTH (SYNCHRO DRIVE SYSTEMS)	31

UNITS <u>WITHOUT</u> DECORATIVE END PANELS	33
UNITS WITH DECORATIVE END PANELS	33
ELECTRICAL MOBILE SYSTEM INSTALLATION	36
POWERPLUS™ MOBILE SYSTEMS	36
P3™ MOBILE SYSTEMS	36
UNITS UP TO 24 FT IN LENGTH (DIRECT DRIVE SYSTEMS)	37
UNITS OVER 25 FT IN LENGTH (SYNCHRO DRIVE SYSTEMS)	37
MISCELLANEOUS INFORMATION	40
DRAWINGS	42

Section

1

INTRODUCTION

Thank you for selecting an Aurora Mobile System. We believe that you will find that the Aurora Mobile System to be a highly efficient and user-friendly system.

SYSTEM BENEFITS

Aurora Mobile Systems makes optimum use of available space by using only one access aisle for each bank of storage racks, when mounted on mobile bases. Aurora Mobile Systems offers twice the storage capacity compared to conventional static shelving occupying the same precious space.

PURPOSE OF MANUAL

This manual is applicable to all Aurora Mobile Systems manufactured by Richards-Wilcox, Inc.

The Richards-Wilcox company policy is one of continuous product improvement. Accordingly, all rights are reserved by Richards-Wilcox to alter specifications at any time without prior notice. While reasonable efforts have been made to ensure that this manual is current and correct at the time of publishing, the descriptions and illustrations appearing herein are not binding.

GENERAL INFORMATION

All components must be checked for defects, size and quantity upon delivery to the job site. Any defect, shortage or component wrongly delivered should be immediately reported.

The installation **must be** performed as per specifications and drawings. Appropriate approval **must be** obtained **prior** to making any alterations to the product or deviating from these installation instructions.

UNAUTHORIZED ALTERATIONS MAY CREATE UNSAFE CONDITIONS AND MAY VOID WARRANTY.

SAFETY



- Comply with applicable safety rules.
- Maintain the installation site in a clean and orderly manner.
- Use appropriate safety equipment (safety shoes, eye protection, gloves, etc.)
- Use appropriate tools

WARRANTY

All components manufactured by Richards-Wilcox, Inc shall be free from defects in workmanship and material for a period of five (5) years from the date of shipment from Richards-Wilcox, Inc. If during the warranty period any covered part is proven defective in either material or workmanship, it will be replaced without charge, freight prepaid. Components and units purchased by Richards- Wilcox, Inc. carry the original manufacturer's warranty.

THIS WARRANTY SHALL BE VOID UNLESS

- Purchaser gives Richards-Wilcox, Inc. immediate notice of defective part or parts.
- Purchaser provides Richards-Wilcox, Inc. the opportunity to inspect and test the claimed defective part(s).
- Material is still in the possession of the original Purchaser/Owner.
- Material is still part of the original installation operating under normal usage: Eight (8) hours per day, five (5) days per week shall constitute normal usage.
- Material has been properly maintained and lubricated.
- That the system installation was proper and according of these instructions.

RICHARDS-WILCOX, INC.'S LIABILITY UNDER THIS WARRANTY SHALL BE LIMITED TO FURNISHING A PART OR PARTS, AS NECESSARY. ANY EXPENSE RELATIVE TO INSTALLATION SHALL NOT BE BORNE BY RICHARDS-WILCOX, INC. EQUIPMENT DAMAGED AS A RESULT OF EXPOSURE TO CORROSIVE OR ABRASIVE SUBSTANCES SHALL NOT BE REPLACED UNDER THIS WARRANTY.

THE ABOVE WARRANTIES DO NOT COVER PARTS, WHICH UPON INSPECTION BY RICHARDS-WILCOX, ARE DETERMINED TO HAVE BEEN SUBJECT TO MISUSE, NEGLIGENCE, ALTERATIONS, ACCIDENT, ABUSE, DAMAGE BY FIRE, FLOOD OR SIMILAR CAUSALITY.

IN NO EVENT SHALL RICHARDS-WILCOX, INC. BE LIABLE FOR INDIRECT OR CONSEQUENTIAL DAMAGES OF ANY NATURE FOR THE INSTALLATION, OPERATION AND USE OF THE SYSTEM.

NOTES

Section

2

TOOLS AND MATERIALS

The following are the recommended tools and materials necessary to properly install an Aurora Mobile System.

REQUIRED:

- SCREWDRIVERS**
 - Phillips - #1 and #2
 - Slotted - #1 and #2

- DRILL**
 - 3/8" variable speed suggested

- DRILL BITS**
 - 3/16"
 - 1/4"
 - 5/16"
 - 3/8"
 - 11/64 masonry bit (5/32" Tapcon)
 - #& (13/64")

- CHALK LINE**

- HAMMER**

- LEVELING DEVICE(S)**
 - Transit
 - Bubble/Torpedo level

- RUBBER Mallet (Primarily for installing shelving)
- UTILITY KNIFE
- TROWEL OR PUTTY KNIFE
- PLIERS, CHANNEL LOCKS OR VISE GRIPS
- OPEN/BOXED END WRENCHES OR 3/8" SOCKET SET
- SMALL TAP SET
- ALLEN WRENCH SETS (Standard and Metric)
- METAL BAND CUTTER
- NONSHRINKING GROUT
- RAIL PLACEMENT DRAWINGS

NOT REQUIRED, BUT HELPFUL

- SCREW GUN
- LASER LEVEL
- HAMMER/PULSATING DRILL

MAKE SURE THAT ALL TOOLS ARE IN PROPER WORKING ORDER BEFORE BEGINNING INSTALLATION

Section
3

RAIL AND RAMP INSTALLATION

The following are the instruction for lay-out and installation of the rail and ramp portions of all Aurora Mobile System.

GENERAL GUIDELINES

Section A is for installation of rails without use of Twin Ramp system.

Section B is for rail installation using Twin Ramp system.

Section C is for rail installation using 4” and 12” ADA ramps

PRIOR to the installation of the rails review **ALL** drawings.

ENSURE THAT ALL RAIL CENTERS AND WHEEL CENTERS ARE THE SAME.

All measurements are in inches.

ALL RAIL MEASUREMENTS ARE TO THE CENTER OF THE RAIL.

Where a system uses the chain and sprocket drive mechanism, check that the chain channel is on the correct side of the rail. (Industrial – 1500 System)

Where a system uses Anti-Tip rails check that the anti-tip channel is on the correct side of the rail.

Where rails are drilled and tapped for End Stops, ensure that rails are correctly placed.

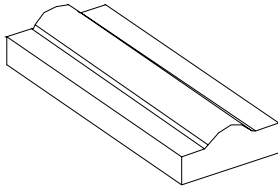

GUIDE RAIL

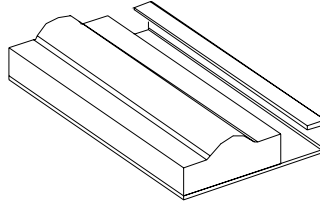

**GUIDE RAIL W/
ANTI-TIP CHANNEL**

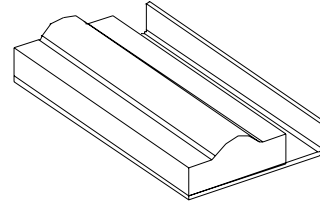

**GUIDE RAIL W/
CHAIN CHANNEL**

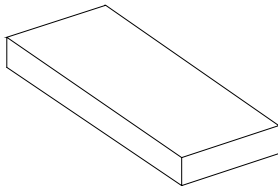

RUNNING RAIL

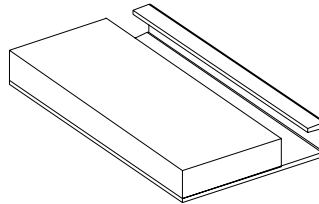

**RUNNING RAIL W/
ANTI-TIP CHANNEL**

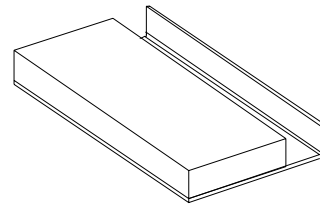

**RUNNING RAIL W/
CHAIN CHANNEL**

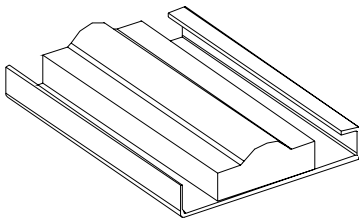

**GUIDE RAIL W/ CHAIN
AND ANTI-TIP CHANNEL**

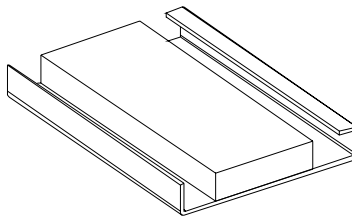

**RUNNING RAIL W/ CHAIN
AND ANTI-TIP CHANNEL**

Figure 1
TYPE OF MOBILE SYSTEM RAILS

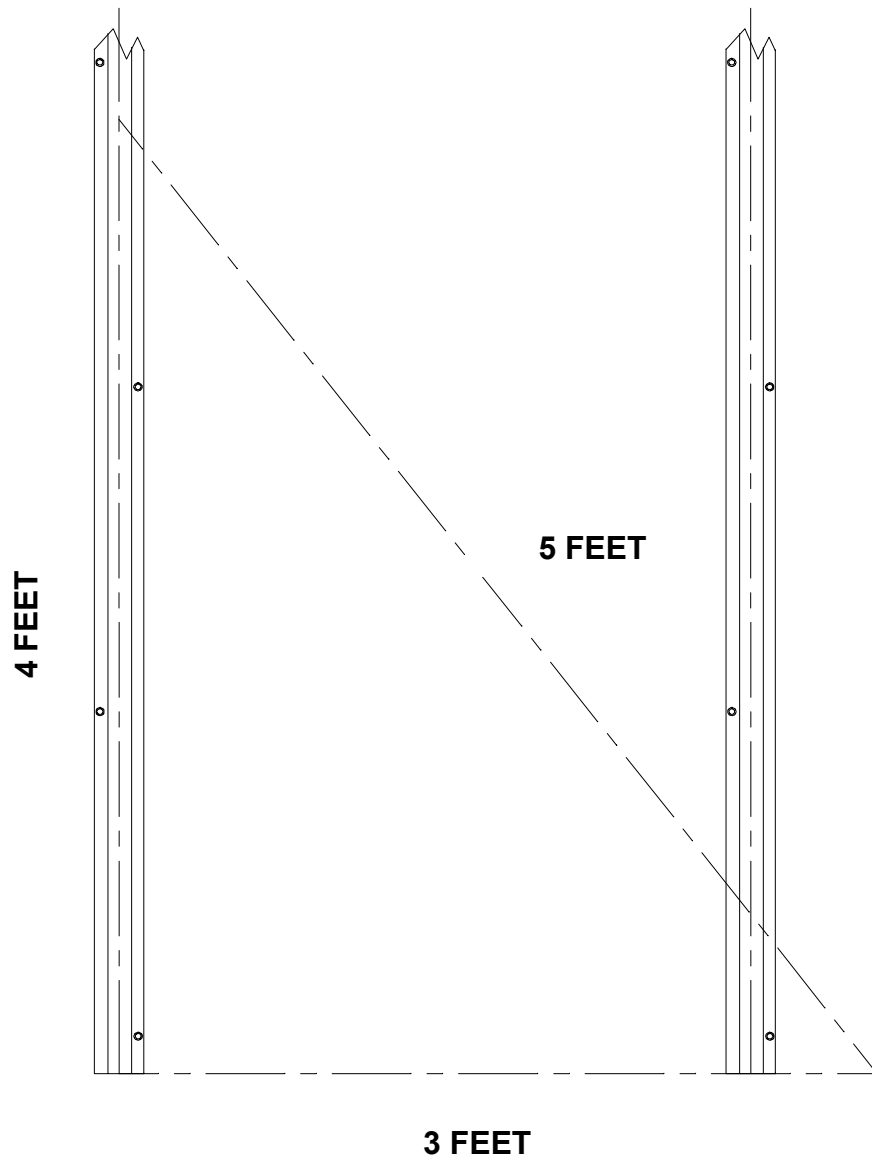

Figure 2
3,4,5 Triangulation Diagram

RAIL INSTALLATION

1. Before beginning rail installation a given reference point (datum) **MUST BE** established. Rails **MUST BE** laid out and installed square to the established datum. This is best obtained by using the 3-4-5 Triangulation Method. (See Figure 2)



NOTE

FAILURE TO PROPERLY ESTABLISH THE DATUM WILL SERIOUSLY AFFECT RAIL INSTALLATION AND MAY CAUSE SYSTEM FAILURES.

To set the datum, identify the location of the “FIRST RAIL.” The FIRST RAIL is the rail that is the farthest rail from the drive end of the carriage. From the base of the rail measure 4’ up the rail and mark this spot. Then from the base, moving 90 degrees to the side, measure 3’ to the side of the FIRST RAIL and mark this spot. Measure the distance between the two marks – this should be 5’. If the measurement is not 5’ adjust the top of the FIRST RAIL accordingly.

Using other fixed points (i.e., a wall,) as the rail reference point (datum) is not recommended unless the datum can be verified as being square.

2. Once the datum has been established and the FIRST RAIL is squared off, using a chalk line, lay out **ALL** of the rail center lines on the floor. Measurements for location of ALL RAILS are to always be made from the FIRST RAIL.



NOTE

RAILS MUST BE POSITIONED TO THE EXACT DIMENSIONS SHOWN ON THE RAIL PLACEMENT DRAWING(S).

3. Once all rail locations have been identified and chalk lines set, center the rails on the chalk line(s).



NOTE

IMPORTANT: When rail(s) come cut in different lengths the splices should be staggered between rails. Rail splices should never be across from one another. **FAILURE TO STAGGER RAIL SPLICES MAY AFFECT SYSTEM OPERATION.**

4. When two (2) pieces of rail need to be spliced together two (2) 5/16" x 1 1/8" steel dowel pins are to be used.

NOTE: Rails are pre-drilled and counter-sunk and can be used as templates for locating anchor holes in the floor. Using the rails as a template, an 11/64" masonry drill bit should be used to drill anchor holes to a depth of at least 3 1/2". All anchor holes should be used. Floor anchors should have a minimum of 1" embedment into the concrete floor.

5. Prior to installing floor anchors, all anchor holes should be cleaned out and be free from dust and debris. If desired, a caulking agent may be used along with the floor anchors. Attach rails to floor using floor anchors. Ensure that the heads of the floor anchors are set within the countersink and are not protruding over the edge.

NOTE: NON-CONCRETE FLOOR RAIL INSTALLATION MUST BE REVIEWED AND APPROVED BY A STRUCTURAL ENGINEER.

6. Once rails are located on the floor they must be leveled. It is vital to proper Mobile System operation that not only are the rails square, but that they are level. **FAILURE TO PROPERLY LEVEL RAILS MAY AFFECT SYSTEM OPERATION.**

NOTE: To level the rails it is recommended that a grid be drawn showing the rails and anchor locations. Using a transit, laser level or other appropriate leveling/measurement device, determine each anchor location height from the floor and record that number on the grid. Once all locations have been measured, find the highest number. This is the highest spot on the floor and will become the reference point (datum) from which all rails will be leveled.

7. Using shims, bring each anchor location level to the highest point. To check for proper level, tighten the floor anchor(s) and check with leveling tool.
8. Once all rails have been brought level, it is essential that all gaps under the rails be filled in thereby providing firm support for the rail. Gaps under the rails should be filled in with a non-shrinking grout. In order to avoid cracking and to ensure proper bonding, the grout should be packed under the rails in one application. Make certain the grout is thoroughly packed under the rails leaving no gaps, spaces or air pockets.
9. After applying grout, perform a final check for level and make appropriate adjustments before the grout cures.

3” and 6” TWIN RAMP INSTALLATION

1. Before beginning twin ramp installation a given reference point (datum) **MUST BE** established. The twin ramp channel(s) **MUST BE** laid out and installed square to the established datum. This is best obtained by using the 3-4-5 Triangulation Method. (See Figure 2)



NOTE

FAILURE TO PROPERLY ESTABLISH THE DATUM WILL SERIOUSLY AFFECT TWIN RAMP CHANNEL AND RAIL INSTALLATION AND MAY CAUSE SYSTEM FAILURES.

To set the datum, identify the location of the “FIRST RAIL.” The FIRST RAIL is the rail that is the farthest rail from the drive end of the carriage. From the base of the rail measure 4’ up the rail and mark this spot. Then from the base, moving 90 degrees to the side, measure 3’ to the side of the FIRST RAIL and mark this spot. Measure the distance between the two marks – this should be 5’. If the measurement is not 5’ adjust the top of the FIRST RAIL accordingly.

Using other fixed points (i.e., a wall,) as the rail reference point (datum) is not recommended unless the datum can be verified as being square.

2. Once the datum has been established and the FIRST RAIL is squared off, using a chalk line lay out **ALL** of the rail center lines on the floor. Measurements for location of ALL RAILS are to always be made from the FIRST RAIL.



NOTE

TWIN RAMP CHANNELS MUST BE POSITIONED TO THE EXACT DIMENSIONS SHOWN ON THE RAIL PLACEMENT DRAWING(S).

3. Once all rail locations have been identified and chalk lines set, center the twin ramp channels on the chalk line(s). If the twin ramp channels come cut in different lengths the channel ends should be placed flush with each other.

4. Place rail in the twin ramp channels. When two (2) pieces of rail need to be spliced together two (2) 5/16" x 1 1/8" steel dowel pins are to be used.

NOTE: When rail(s) come cut in different lengths the splices should be staggered between rails. Rail splices should never be across from one another. **FAILURE TO STAGGER RAIL SPLICES MAY AFFECT SYSTEM OPERATION**

Rails are pre-drilled and counter-sunk and can be used as templates for locating anchor holes in the floor. Using the rails as a template, an 11/64" masonry drill bit should be used to drill anchor holes to a depth of at least 3 1/2". All anchor holes should be used. Floor anchors should have a minimum of 1" embedment into the concrete floor.

5. Prior to installing floor anchors, all anchor holes should be cleaned out and be free from dust and debris. If desired, a caulking agent may be used along with the floor anchors. Attach rails to floor using floor anchors. Ensure that the heads of the floor anchors are set within the countersink and are not protruding over the edge.

NOTE: NON-CONCRETE FLOOR TWIN RAMP AND RAIL INSTALLATIONS MUST BE REVIEWED AND APPROVED BY A STRUCTURAL ENGINEER.

6. Once twin ramp channels and rails have been positioned on the floor they must be leveled. It is vital to proper Mobile System operation that not only is the twin ramp channel square but that they are also level.

FAILURE TO PROPERLY LEVEL TWIN RAMP CHANNELS AND RAILS MAY AFFECT SYSTEM OPERATION.

7. To level the twin ramp channels and rails it is recommended that a grid be drawn showing the twin ramp channels, rails and anchor locations. Using a transit, laser level or other appropriate leveling/measurement device, determine each anchor location height from the floor and record that number on the grid. Once all locations have been measured, find the highest number. This is the highest spot on the floor and will become the reference point (datum) from which all twin ramp channels and rails will be leveled.

8. At the highest spot, secure the twin ramp channel and rail to the floor using appropriate floor anchors.
9. Using shims, bring all other twin ramp channel and rail anchor locations level to the highest point. To check for proper level, tighten the floor anchor(s) and check with leveling tool.
10. Once all rails have been brought level, it is essential that all gaps under the track be filled in thereby providing firm support for the rail. Gaps under the rails should be filled in with a non-shrinking grout. In order to avoid cracking and to ensure proper bonding, the grout should be packed under the tracks in one application. Make certain the grout is thoroughly packed under the rails leaving no gaps, spaces or air pockets.
11. Hook twin ramps into ramp channel assembly. If more than one section ensure that the ends are set flush to each other.
12. After applying grout, perform a final check for level and make appropriate adjustments before the grout cures.
13. Attach rail to flooring with appropriate fasteners.

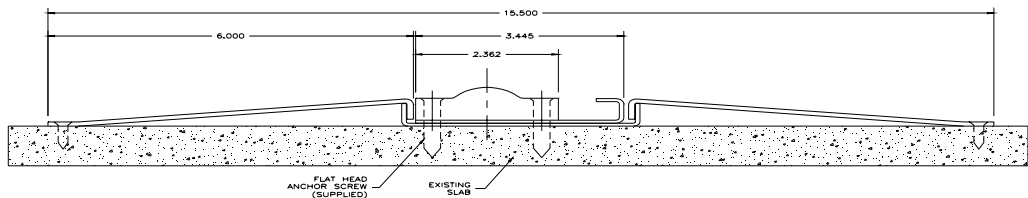

Figure 3
SECTION VIEW OF TWIN RAMP INSTALLATION

4” and 12” ADA RAMP INSTALLATION

ONLY USED IN FALSE FLOORING OR DECKING INSTALLATIONS. SEE SECTION 8 FOR FALSE FLOOR INFORMATION

1. Before beginning rail installation a given reference point (datum) **MUST BE** established. Rails **MUST BE** laid out and installed square to the established datum. This is best obtained by using the 3-4-5 Triangulation Method. (See Figure 2)



NOTE

FAILURE TO PROPERLY ESTABLISH THE DATUM WILL SERIOUSLY AFFECT RAIL INSTALLATION AND MAY CAUSE SYSTEM FAILURES.

To set the datum, identify the location of the “FIRST RAIL.” The FIRST RAIL is the rail that is the farthest rail from the drive end of the carriage. From the base of the rail measure 4’ up the rail and mark this spot. Then from the base, moving 90 degrees to the side, measure 3’ to the side of the FIRST RAIL and mark this spot. Measure the distance between the two marks – this should be 5’. If the measurement is not 5’ adjust the top of the FIRST RAIL accordingly

Using other fixed points (i.e., a wall), as the rail reference point (datum) is not recommended unless the datum can be verified as being square.

2. Once the datum has been established and the FIRST RAIL is squared off, using a chalk line, lay out **ALL** of the rail center lines on the floor. Measurements for location of ALL RAILS are to always be made from the FIRST RAIL.

RAILS MUST BE POSITIONED TO THE EXACT DIMENSIONS SHOWN ON THE RAIL PLACEMENT DRAWING(S).

3. Once all rail locations have been identified and chalk lines set, center the rails on the chalk line(s).



NOTE

IMPORTANT: When rail(s) come cut in different lengths the splices should be staggered between rails. Rail splices should never be across

from one another. **FAILURE TO STAGGER RAIL SPLICES MAY AFFECT SYSTEM OPERATION.**

4. When two (2) pieces of rail need to be spliced together two (2) 5/16" x 1 1/8" steel dowel pins are to be used.

Rails are pre-drilled and counter-sunk and can be used as templates for locating anchor holes in the floor. Using the rails as a template, an 11/64" masonry drill bit should be used to drill anchor holes to a depth of at least 3 1/2". All anchor holes should be used. Floor anchors should have a minimum of 1" embedment into the concrete floor.

5. Prior to installing floor anchors, all anchor holes should be cleaned out and be free from dust and debris. If desired, a caulking agent may be used along with the floor anchors. Attach rails to floor using floor anchors. Ensure that the heads of the floor anchors are set within the countersink and are not protruding over the edge.

NOTE

NOTE: NON-CONCRETE FLOOR RAIL INSTALLATION MUST BE REVIEWED AND APPROVED BY A STRUCTURAL ENGINEER.

6. Once rails are located on the floor they must be leveled. It is vital to proper Mobile System operation that not only are the rails square but also that they are level. **FAILURE TO PROPERLY LEVEL RAILS MAY AFFECT SYSTEM OPERATION.**

To level the rails it is recommended that a grid be drawn showing the rails and anchor locations. Using a transit, laser level or other appropriate leveling/measurement device, determine each anchor location height from the floor and record that number on the grid. Once all locations have been measured, find the highest number. This is the highest spot on the floor and will become the reference point (datum) from which all rails will be leveled.

7. Using shims, bring each anchor location level to the highest point. To check for proper level, tighten the floor anchor(s) and check with leveling tool.
8. Once all rails have been brought level, it is essential that all gaps under the track be filled in thereby providing firm support for the rail. Gaps under the rails should be filled in with a non-shrinking grout. In order to avoid cracking and to ensure proper bonding, the grout should be packed under the tracks in one application. Make certain the grout is thoroughly packed under the rails leaving no gaps, spaces or air pockets.

9. After applying grout, perform a final check for level and make appropriate adjustments before the grout cures.
10. Install false flooring or decking. See Section 8 for false floor information.
11. Whatever material is used for the false floor or decking ensure that a minimum of a 1" strip of flooring or decking is placed on the outside edge of the first/last rail and secure to the floor.
12. Take 4" or 12" ADA Ramp and bring flush with outside rail ensuring that the top of the ramp rests solidly on the false flooring/decking strip and attach with appropriate hardware.

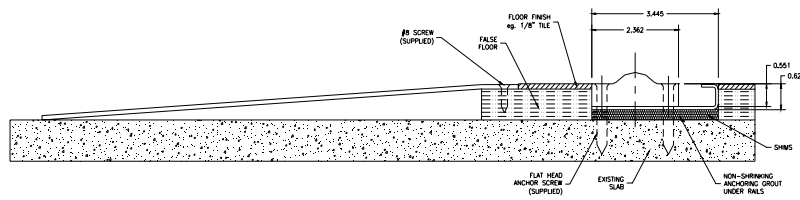

Figure 4
SECTION VIEW OF 12" ADA RAMP

END STOP INSTALLATION

1. If Static Base are not to be used in the system installation, End Stops **MUST BE** attached on the outermost rails.
2. If rails are not factory pre-drilled, place End Stop on top of rail and bring flush to the end of the rail.
3. Using the End Stop as a template, drill and tap rail for 3/8" – 16 mounting screw.
4. Attach End Stops with appropriate fastener.

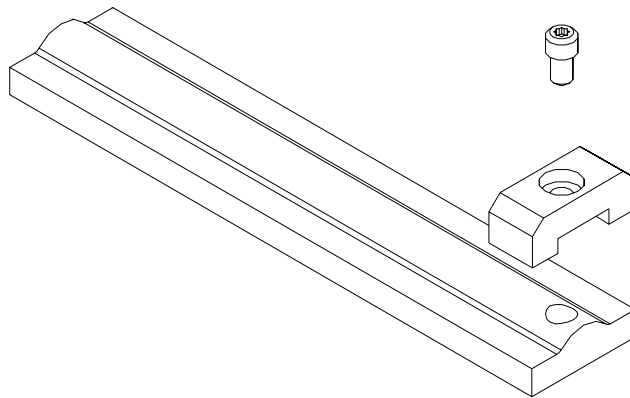

Figure 5
DETAIL VIEW OF END STOP ON GUIDE RAIL

CHAIN-IN-FLOOR RAIL

1. Prior to mounting any bases, if used, the floor chain assembly must be laid in the chain channel and secured at each end. (See Figure 6)

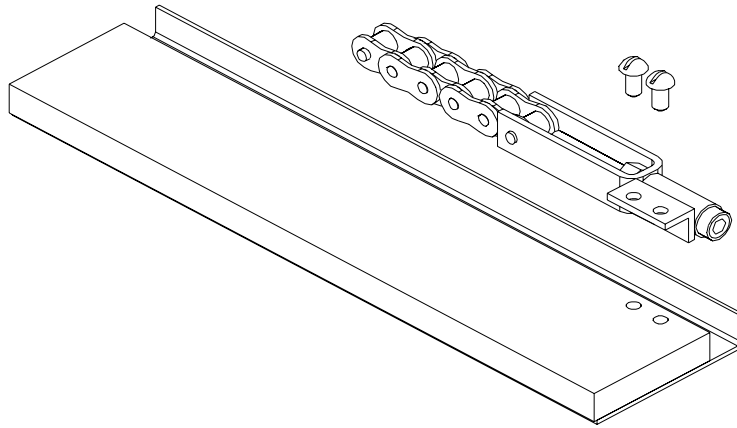

Figure 6

2. As necessary, tension the chain by adjusting the take-up bolt.



RAMP AND RAIL INSTALLATION COMPLETE

**DOUBLE CHECK ALL WORK BEFORE
PROCEEDING TO NEXT SECTION**

NOTES:

Section
4

STATIC BASE INSTALLATION

The following are the instructions for lay-out and installation of the Static Base portions of Aurora Mobile Systems.

GENERAL

Before beginning actual layout and installation, review this section and ensure that all materials and tools are available.

STATIC BASE INSTALLATION INSTRUCTION

1. Select one of the mobile bases and place on the rails. If there is more than one (1) section, bolt all sections together using the supplied splice plates and bolts. (See Figure 7).

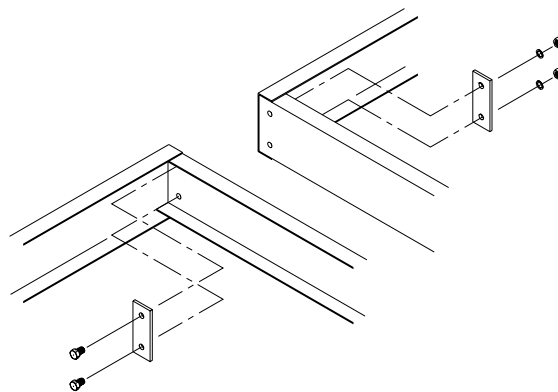

Figure 7

2. If necessary, adjust the wheels to ensure that the concave guide wheels fit squarely on the raised (convex) portion of the rail. (See Figure 8).

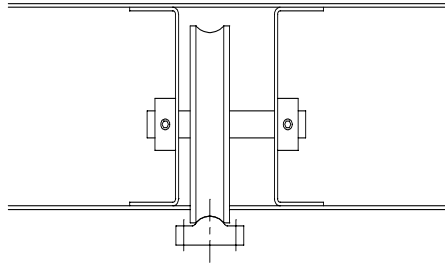

Figure 8

3. Place static base on the rails as indicated on the rail placement drawing(s). If there is more than one (1) section, bolt all sections together using the supplied splice plates and bolts. (See Figure 7).
4. Align the static base with the mobile base.
5. Place static base clips on rail as shown in Figure 9.

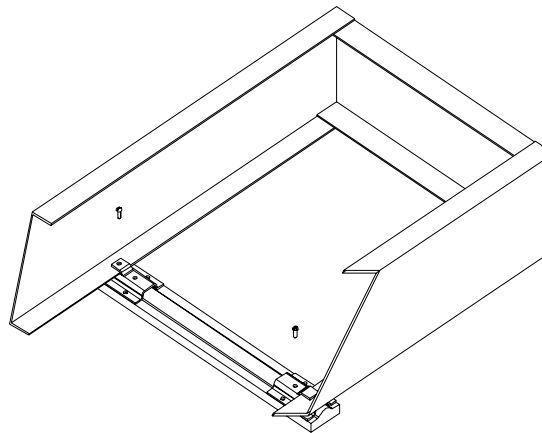

Figure 9

6. Using a #7 (13/64") drill bit and a 1/4-20 tap, drill and tap holes using static base clips as templates.

NOTE: Ensure that the hole is drilled and tapped to sufficient depth for proper screw engagement.

NOTE: A minimum of one (1) hole must be drilled and tapped through carriage flange as per Figure 3.

7. Using supplied fasteners, secure the static base clips to the static base/rails



**STATIC BASE INSTALLATION COMPLETE.
DOUBLE CHECK ALL WORK BEFORE
PROCEEDING TO NEXT SECTION**

NOTES

Section

5

HAND-PUSH MOBILE BASE INSTALLATION

The following section sets forth the instructions for the lay-out and installation of the Mobile Base portions of all Hand-Push models for Aurora Mobile Systems - Low Profile (3750) and Office 1000 (3100).

GENERAL

Before beginning actual layout and installation, review this section and ensure that all materials and tools are available.

Confirm the model type (number) being installed and follow the instructions for that particular model.

All references to shelving assume the use of Aurora Shelving Products.

HAND-PUSH BASE INSTALLATION

1. Place mobile bases on the rails. If there is more than one (1) section, bolt all sections together using the supplied splice plates and bolts. (See Figure 7).
2. If necessary, adjust the wheels to ensure that the concave guide wheels fit squarely on the raised (convex) portion of the rail. (See Figure 8).
3. If using Anti-Tip rails, attach Anti-Tip Clips to wheel-set crossbeam ensuring that the fasteners threads face downwards.

- Using the Rail Placement drawing(s), on the left hand side of each base, locate holes for bumper installation and install bumpers as per drawings using supplied fasteners.

NOTE: For proper and safe operation a minimum of two (2) bumpers **MUST BE** installed on each mobile base.

SYSTEMS LESS THAN 48" LONG WITH NO DECORATIVE END PANELS

- Install crossbeam frame cover to front crossbeam.
- Install handle frame to crossbeam frame cover.
- Attach handle to handle frame through handle cover.
- Attach handle cover to handle frame.

SYSTEMS LONGER THAN 48" LONG WITH NO DECORATIVE END PANELS

- Install handle frame to front cross beam.
- Attach handlecover to handle frame through handle cover.
- Attach handle cover to handle frame.

ALL SYSTEMS WITH DECORATIVE END PANELS

- Position shelving uprights on each end of the mobile base or, if longer than 48", position one (1) end upright and one (1) middle (Intermediate) upright; temporarily secure the two (2) shelving uprights using at least two (2) shelving supports.

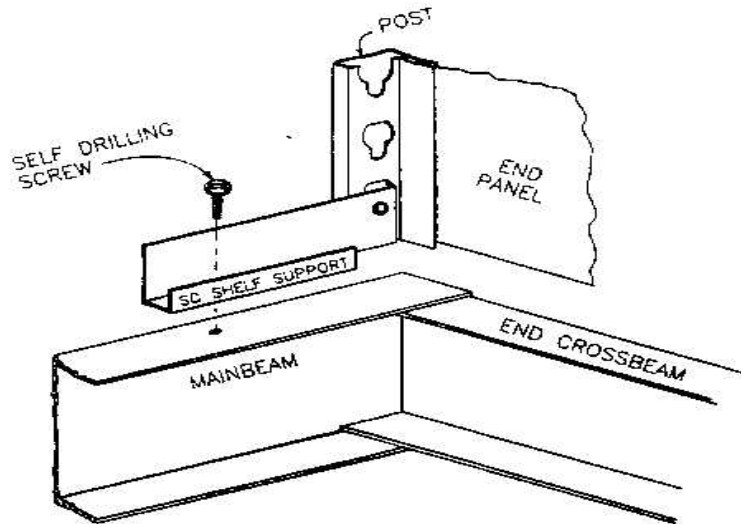

Figure 10

13. Using two (2) single rivet shelf supports (“SC”), attach shelf support to bottom-most mounting holes (“key-holes”) so that the shelf supports lie on top of (flush) to the mobile bases.
 14. Secure shelf supports to mobile base with supplied fasteners through holes in lower shelf support. (See Figure 10).
 15. Place end panel against the front of the shelving upright and flush with the sides and bottom of the mobile base.
 16. Once fully aligned, working from the inside of the shelving upright, drill pilot holes through the upright post and into the decorative end panel frame.
- NOTE:** Be careful when drilling pilot holes not to drill too close to the edges or to drill through the exterior surface of the end panel.
17. Attach end panel to shelving upright using appropriate fasteners.

18. For proper operation, the center of the handle **MUST BE** positioned 38 3/16" from the bottom of the end panels and **MUST BE** centered (side-to-side) on the end panels.
 - a. To determine the correct location for handle placement, measure 38 3/16" from the bottom edge of the panel and mark the location. This marks the center position of the handle.
 - b. From the **outside** edge of the end panel, measure to the other **outside** edge. Note the distance and divide in half.
19. From the outside edge of the end panel measure to the half-way point determined in Step 18 (b) above.
20. Using the handle as a template, place handle on the center points and mark the bolt handles on the panel.
21. Remove the handle and drill through the panel and shelving Upright.
22. Attach handle to end panel with supplied fasteners.
23. Repeat for all end panels and handles.

HAND-PUSH MOBILE BASE INSTALLATION COMPLETE



**DOUBLE CHECK ALL WORK BEFORE
PROCEEDING TO SHELVING INSTALLATION.**

Section

6

MECHANICAL ASSIST MOBILE BASE INSTALLATION

The following section sets forth the instructions for the lay-out and installation of the Mobile Base portions of all Mechanical Assist models for Aurora Mobile Systems - Low Profile (3750), Office 1000 (3100) and Industrial (1500).

GENERAL

Before beginning actual layout and installation, review this section and ensure that all materials and tools are available.

Confirm the model type (number) being installed and follow the instructions for that particular model.

All references to shelving are to Aurora Shelving Products.

LOW PROFILE (3750) INSTALLATION

1. Place mobile bases on the rails. If there is more than one (1) section, bolt all sections together using the supplied splice plates and bolts. (See Figure 7).

2. If necessary, adjust the wheels to ensure that the concave guide wheels fit squarely on the raised (convex) portion of the rail. (See Figure 8).
3. Using Rail Placement drawing(s), on the left hand side of each base, locate holes for bumper installation and install bumpers as per drawings using supplied fasteners.
4. Slide Torque Tubes over drive shaft.
5. Line up the holes in the Torque Tube and the drive shaft and fasten together with appropriate fasteners.

UNITS WITHOUT DECORATIVE END PANELS

1. Align chain box assembly mounting holes with holes in mobile base at the drive end of the base. (See Figure 11)

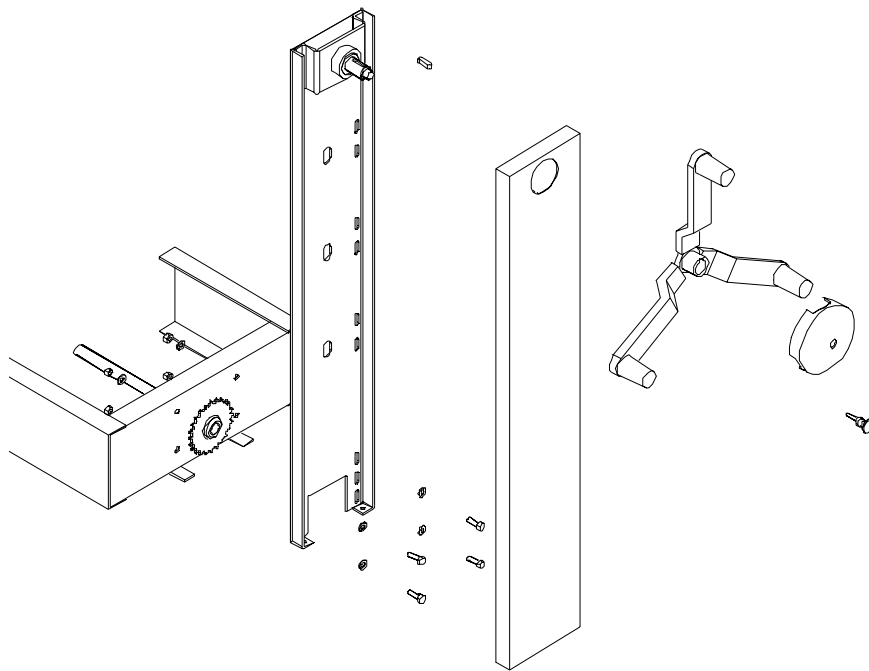

Figure 11

2. Loop chain around the lower transmission sprocket.
3. Using provided fasteners, attach chain box assembly bringing nuts “finger” tight.
4. Using the jackscrews (See Figure 12) lift the chain box assembly to remove **all slack** from the chain and tighten the mounting bolts.

NOTE: For proper operation, ensure that chain box is vertically plumb

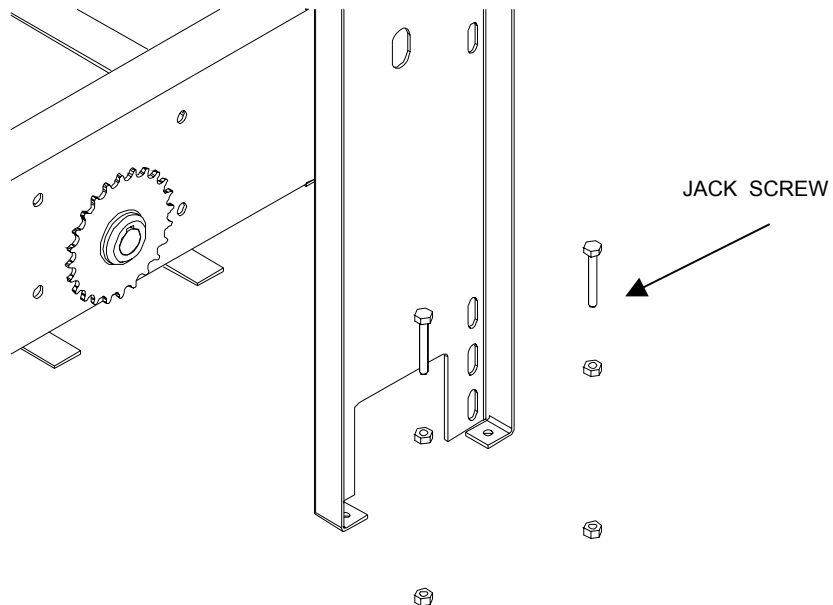

Figure 12

5. Roll mobile base back and forth to check for smooth operation and movement.

NOTE: Smooth running of the base may be affected by adjustment of the chain tension.

6. Place chain box cover over chain box assembly and attach with supplied fasteners.

UNITS WITH DECORATIVE END PANELS

1. Align chain box assembly mounting holes with holes in mobile base at the drive end of the base. (See Figure 11)
2. Loop chain around the lower transmission sprocket.
3. Attach chain box assembly using provided fasteners bringing nuts “finger” tight.
4. Using the jack screws (see Figure 12) lift the chain box assembly to remove **all slack** from the chain and tighten the mounting bolts.

NOTE: For proper operation, ensure that chain box is vertically plumb

5. Roll mobile base back and forth to check for smooth operation and movement.

NOTE: Smooth running of the base may be affected by adjustment of the chain tension

6. Position shelving uprights on each end of the mobile base or, if larger than 48”, position one (1) end upright and one (1) middle (Intermediate) upright.
7. Temporarily secure the two (2) shelving uprights using two (2) shelving supports.
8. Using two (2) single rivet shelf supports (“SC”), attach shelf supports to bottom-most mounting holes (“key-holes”) so that the shelf supports lie on top of (flush) to the mobile bases.
9. Secure shelf supports to mobile base with supplied fasteners through holes in lower shelf support. (See Figure 10).
10. Place end panel against the front of the shelving upright and flush with the sides and bottom of the mobile base.
11. Once fully aligned, working from the inside of the shelving upright, drill pilot holes through the upright post and into the decorative end panel frame.

NOTE: When drilling pilot holes do not drill too close to the edges or drill through the exterior surface of the end panel.

12. Attach end panel to shelving upright using appropriate fasteners.

13. Install key and handcrank.

NOTE: For ease of installation, bring the key in as near upright position (12 o'clock) as is possible.

14. Secure handcrank with set screws.

NOTE: TO PREVENT DAMAGE TO INTERNAL THREADS IN HANDCRANK CASTING DO NOT OVER TORQUE SET SCREWS.

15. Screw in "Anti-Drift" knob in the center of handcrank.

**LOW PROFILE MECHANICAL ASSIST MOBILE BASE
INSTALLATION COMPLETE.**



**DOUBLE CHECK ALL WORK BEFORE PROCEEDING
WITH SHELVING INSTALLATION**

OFFICE 1000 (3100) AND INDUSTRIAL (1500) INSTALLATION

1. Place mobile bases on the rails. If there is more than one (1) section, bolt all sections together using the supplied splice plates and bolts. (See Figure 7).
2. If necessary, adjust the wheels to ensure that the concave guide wheels fit squarely on the raised (convex) portion of the rail. (See Figure 8).
3. Using Rail Placement drawing(s), on the left hand side of each base, locate holes for bumper installation and install bumpers as per drawings using supplied fasteners.
4. Assemble drive shafts as follows:

UNITS UP TO 24 FT IN LENGTH (DIRECT DRIVE SYSTEMS)

1. Line up direct drive shaft(s) with coupling(s).
2. Secure direct drive shafts in coupling using appropriate fasteners.

UNITS OVER 25 FT IN LENGTH (SYNCHRO DRIVE SYSTEMS)

1. Lay out drive tubes as per applicable drawings.
2. Install drive tube collar and gib key. (See Figure 13)
3. If necessary, loosen mobile base connecting bolts enough to allow connection of drive tubes.
4. In connecting drive tubes, ensure that shaft is inserted until even with scribe line on shaft (at least 2" engagement).
5. Secure drive tubes.
6. Re-tighten mobile base connecting fasteners.

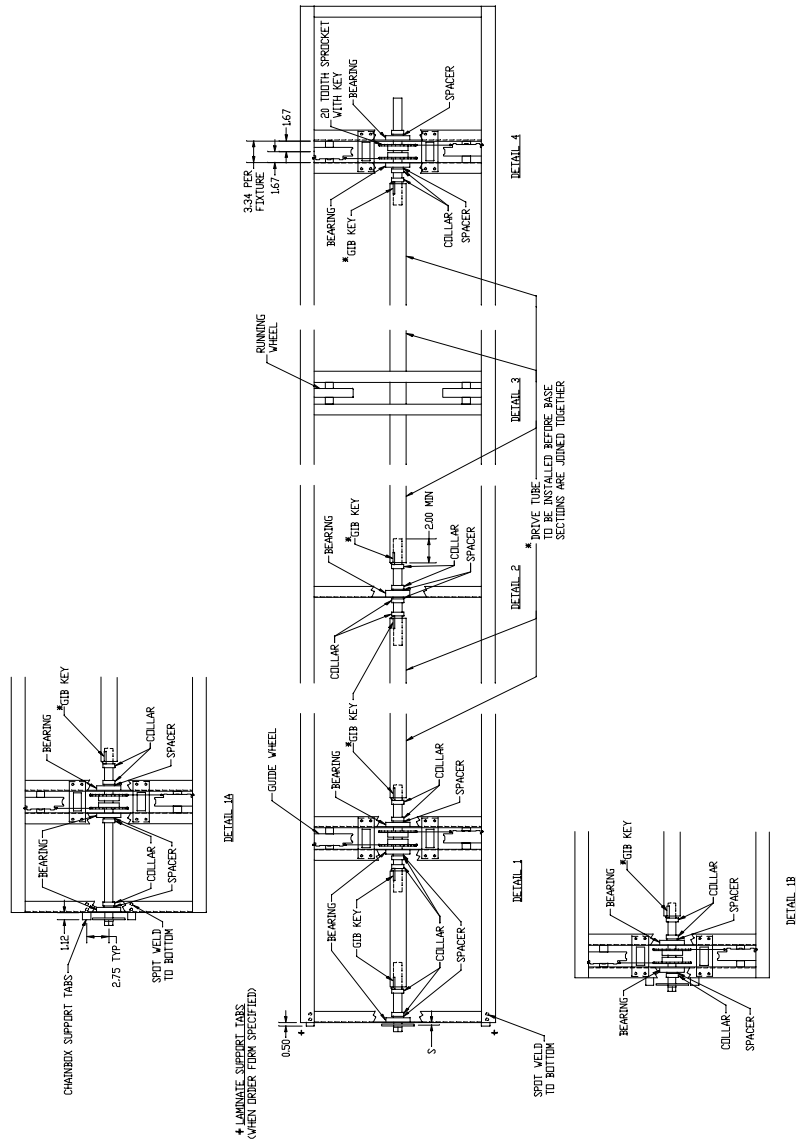

Figure 13
DETAIL VIEWS OF SYNCHRO DRIVE SYSTEM

UNITS WITHOUT DECORATIVE END PANELS

1. Align chain box assembly mounting holes with holes in mobile base at the drive end of the base. (See Figure 11)
2. Loop chain around the lower transmission sprocket.
3. Using provided fasteners, attach chain box assembly bringing nuts “finger” tight.
4. Using the jackscrews (See Figure 12) lift the chain box assembly to remove **all slack** from the chain and tighten the mounting bolts.

NOTE: Ensure that chain box is vertically plumb.

5. Roll mobile base back and forth to check for smooth operation and movement.

NOTE: Smooth running of the base may be affected by adjustment of the chain tension.

6. Place chain box cover over chain box assembly and attach with supplied fasteners.

UNITS WITH DECORATIVE END PANELS

(Units with Euro Panels see separate instructions)

1. Align chain box assembly mounting holes with holes in mobile base at the drive end of the base. (See Figure 11)
2. Loop chain around the lower transmission sprocket.
3. Attach chain box assembly using provided fasteners bringing nuts “finger” tight.
4. Using the jackscrews (see Figure 12) lift the chain box assembly to remove **all slack** from the chain and tighten the mounting bolts.

NOTE: Ensure that chain box is vertically plumb

5. Roll mobile base back and forth to check for smooth operation and movement.

NOTE: Smooth running of the base may be affected by adjustment of the chain tension.

6. Position shelving uprights on each end of the mobile base or, if larger than 48", position one (1) end Upright and one (1) middle (Intermediate) upright.
7. Temporarily secure the two (2) shelving uprights using two (2) shelving supports.
8. Using two (2) single rivet shelf supports ("SC"), attach shelf supports to bottom-most mounting holes ("key-holes") so that the shelf supports lie on top of (flush) to the mobile bases.
9. Secure shelf supports to mobile base with supplied fasteners through holes in lower shelf support. (See Figure 10).
10. Place end panel against the front of the shelving upright and flush with the sides and bottom of the mobile base.
11. Once fully aligned, working from the inside of the shelving upright, drill pilot holes through the upright post and into the decorative end panel frame.

NOTE: When drilling pilot holes do not drill too close to the edges or drill through the exterior surface of the end panel.

12. Attach end panel to shelving Upright using appropriate fasteners.
13. Install key and handcrank
14. Secure handcrank with set screws.

NOTE: TO PREVENT DAMAGE TO INTERNAL THREADS IN HANDCRANK CASTING DO NOT OVER TORQUE SET SCREWS.

15. Screw in "Anti-Drift" knob in the center of handcrank.



**OFFICE 1000 (3100) AN INDUSTRIAL (1500) MECHANICAL
ASSIST MOBILE BASE INSTALLATION COMPLETE.**

**DOUBLE CHECK ALL WORK BEFORE PROCEEDING
WITH SHELVING INSTALLATION**

Section

7

ELECTRICAL MOBILE SYSTEM INSTALLATION

The following section sets forth the basic instructions for the installation of PowerPlus™ and P3™ Mobile Systems.

GENERAL

These installation instructions are for use with electrical mobile systems using an Office 1000 Mobile System with either Direct or Synchro Drives.

POWERPLUS™ MOBILE SYSTEMS

1. Follow all previous instructions for installation of rail and ramps and for setting Static and Mobile Bases.
2. Refer to PowerPlus™ Installation Manual (Richards-Wilcox, Inc. Part Number 3111.00050) for all further instructions on installation of wiring and setting of controls.

P3™ MOBILE SYSTEMS

1. Follow all previous instructions for installation of rail and ramps and installation of decorative end panels, if any.

2. Carriage identification and placement is **critical** to proper installation and operation of P3™ Mobile Systems. Before assembly, refer to the applicable drawings and specifications and identify the following bases and all related components:
 - Static Base, if any;
 - Electric “First Base” (generally, the left most moveable base); and,
 - Moveable bases.
3. If there are multiple sections for the bases, the front and back sections are critical. Middle sections are universal.
4. Identify the Electric First Base and position on the rails in accordance to the system configurations diagrams (See Section 9)
5. Place all remaining mobile bases on the rails. If there is more than one (1) section, bolt all sections together using the supplied splice plates and bolts. (See Figure 7).
6. If necessary, adjust the wheels to ensure that the concave guide wheels fit squarely on the raised (convex) portion of the rail. (See Figure 8).
7. Using Rail Placement drawing(s), on the left hand side of each base, locate holes for bumper installation and install bumpers as per drawings using supplied fasteners.
8. Assemble drive shafts as follows:

UNITS UP TO 24 FT IN LENGTH (DIRECT DRIVE SYSTEMS)

- I. Line up direct drive shaft(s) with coupling(s).
- II. Secure direct drive shafts in coupling using appropriate fasteners.

UNITS OVER 25 FT IN LENGTH (SYNCHRO DRIVE SYSTEMS)

- I. Lay out drive tubes as per applicable drawings.
- II. Install drive tube collar and gib key. (See Figure 13)
- III. If necessary, loosen mobile base connecting bolts enough to allow connecting of drive tubes.

- IV. In connecting drive tubes, ensure that shaft is inserted until even with scribe line on shaft (at least 2" engagement).
 - V. Secure drive tubes.
 - VI. Re-tighten mobile base connecting fasteners.
9. Attach Control Box bracket in moveable bases.
- NOTE:** Control Box bracket may be mounted on either the front (lead) main beam or the cross-beam provided, however, the Control Box bracket **must be** located within that section that is between the front (lead) beam and the first wheel section.
10. Refer to P3™ Installation Manual for all further instructions on installation of wiring and setting of controls.



**INSTALLATION OF RAIL AND CARRIAGE FOR
ELECTRICAL MOBILE SYSTEMS COMPLETE.**

**DOUBLE CHECK ALL WORK BEFORE PROCEEDING
WITH CONTROLS INSTALLATION.**

NOTES

Section
8

MISCELLANEOUS INFORMATION

The following section provides miscellaneous information that may be helpful during installation of Aurora Mobile Systems.

FALSE FLOOR INSTALLATIONS

1. 4" or 12" ADA Ramps are used in False Floor (Decking) installations.
2. Depending on User preferences, different materials may be used for "decking" to fill the spaces between the rails tracks and to bring the floor level to the top of the rails.
3. No specific recommendation is made as materials or installation methods of false flooring (decking).
4. Any false floor or decking used must, however, be leveled to the flat part of the rails and should not extend beyond this height.

NOTE 

IMPORTANT: False flooring or decking that extends over the height of the flat part of the rails may seriously affect mobile system operation

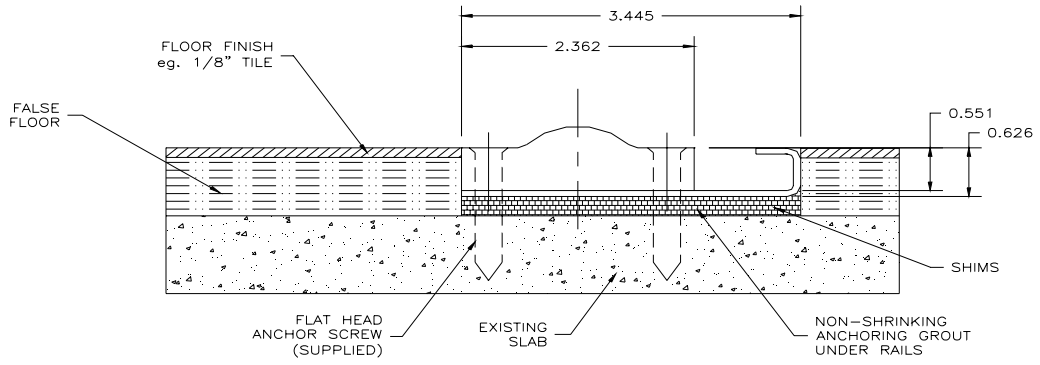

Figure 11
SECTION VIEW THROUGH ANTI-TIP RAIL WITH FALSE FLOOR

Section
9

DRAWINGS

The following section includes larger view of drawings.

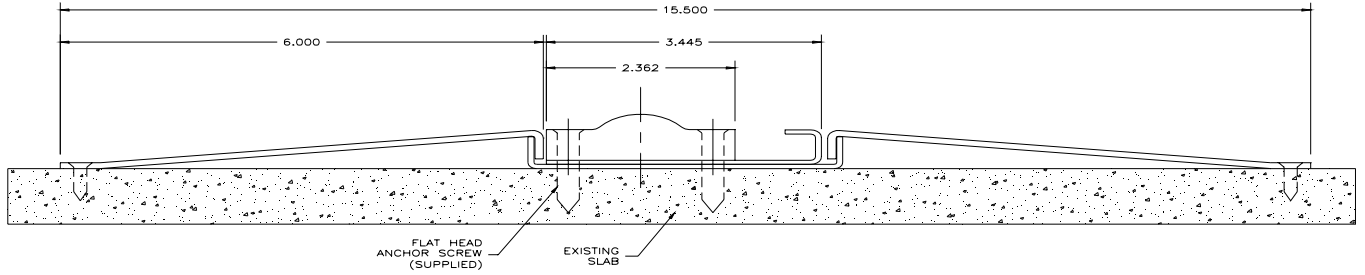

Figure 3
 SECTION VIEW OF TWIN RAMP

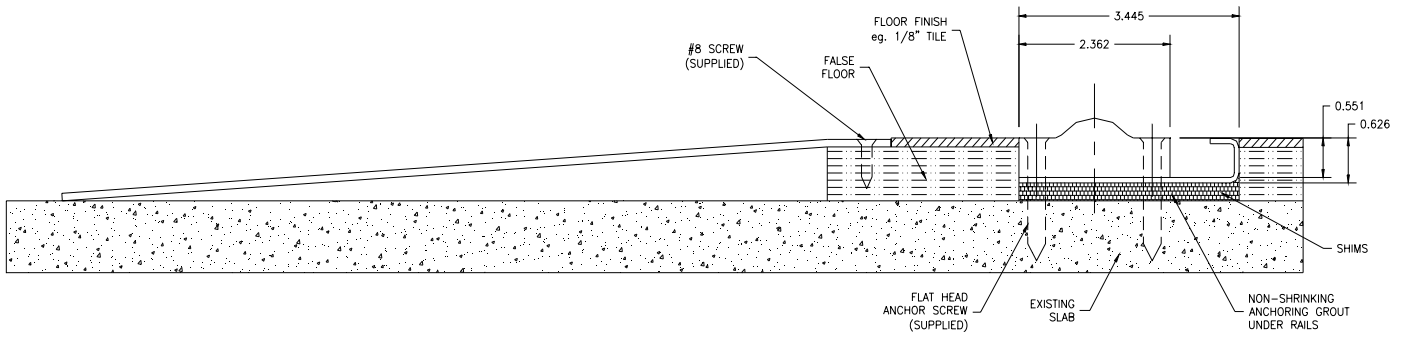

Figure 4
 SECTION VIEW OF 12" ADA RAMP

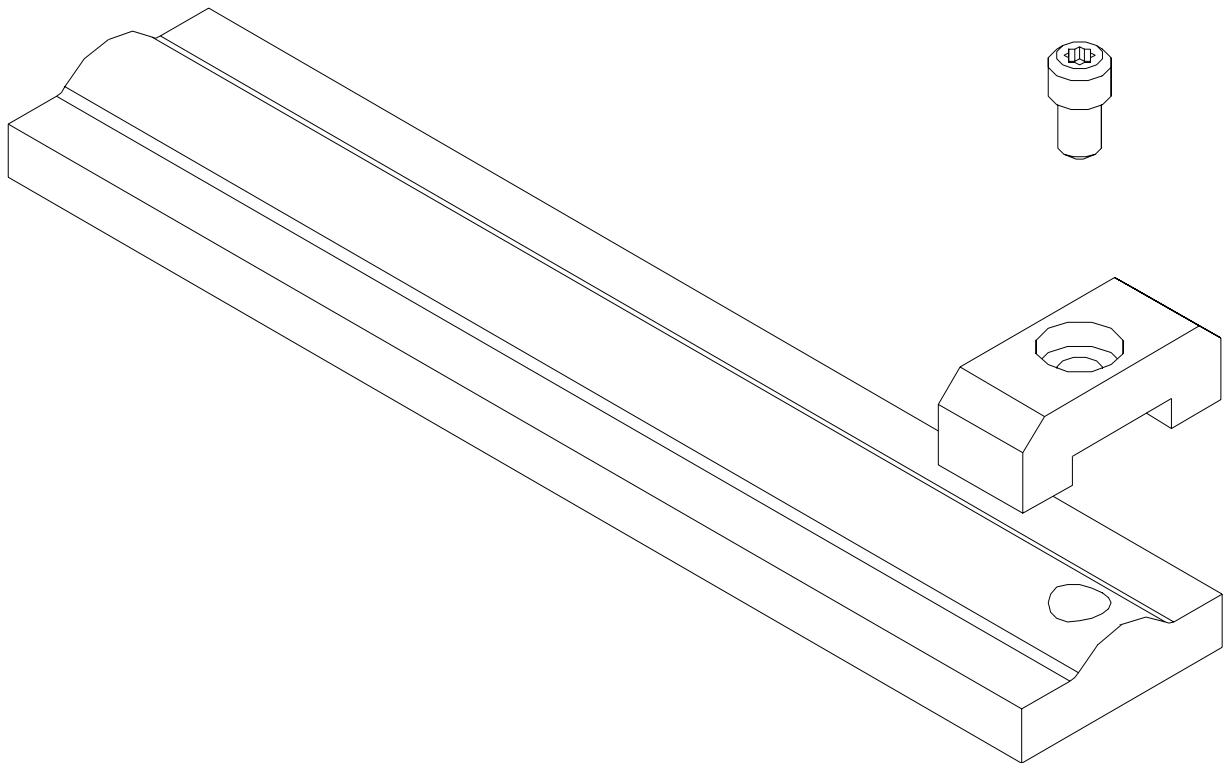

Figure 5
DETAIL VIEW OF END STOP ON GUIDE RAIL

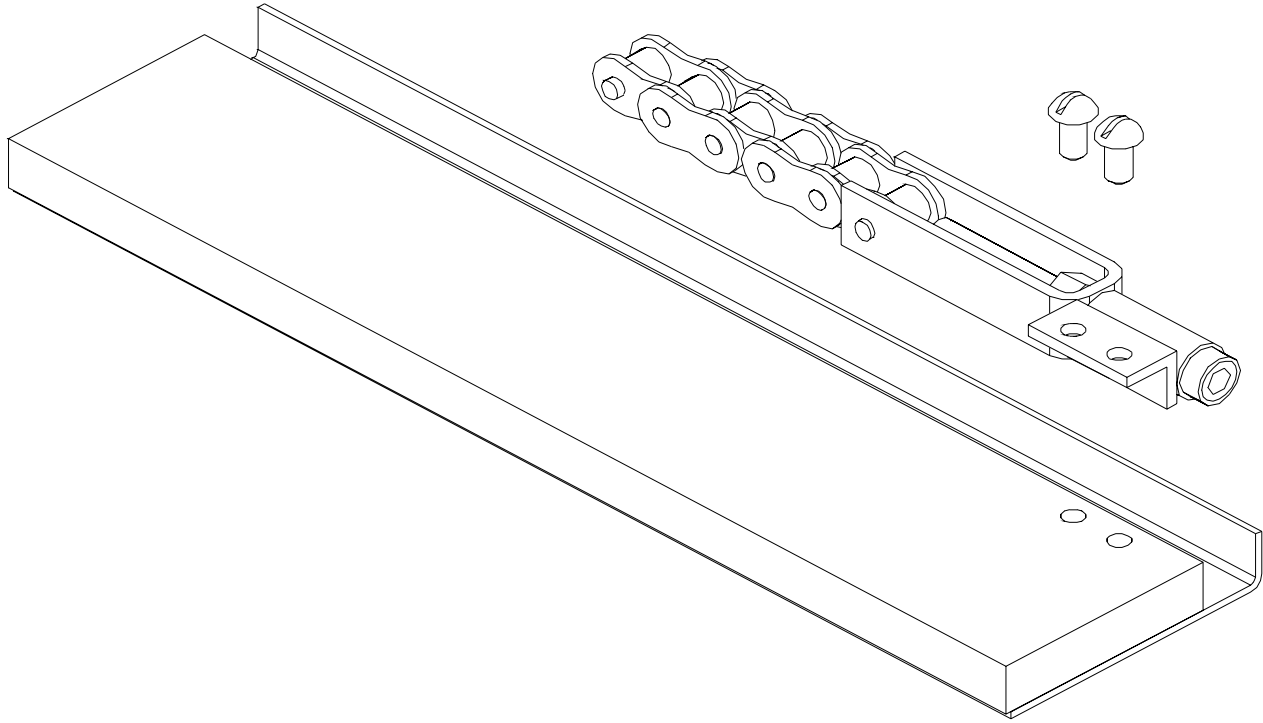

Figure 6
CHAIN-IN-FLOOR RAIL

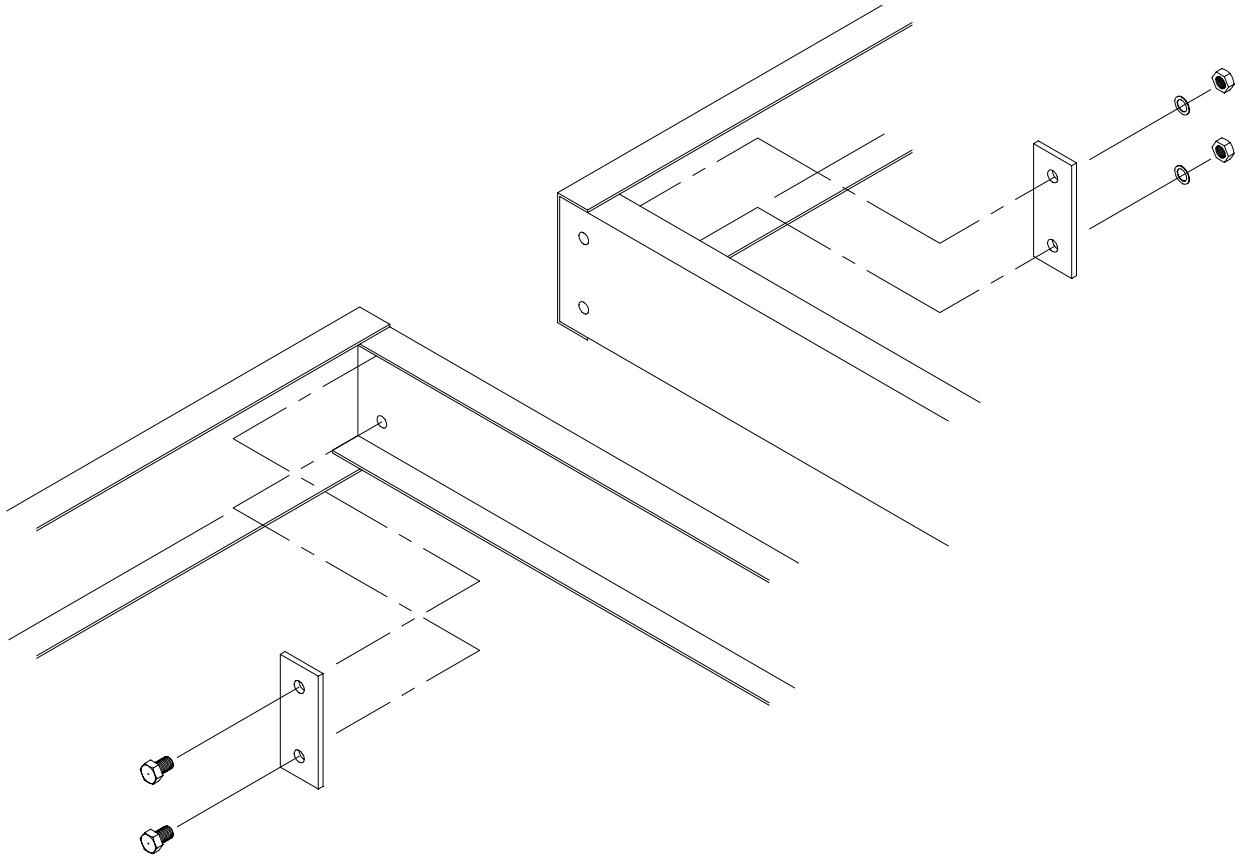

Figure 7
DETAIL VIEW OF CARRIAGE SPLICE

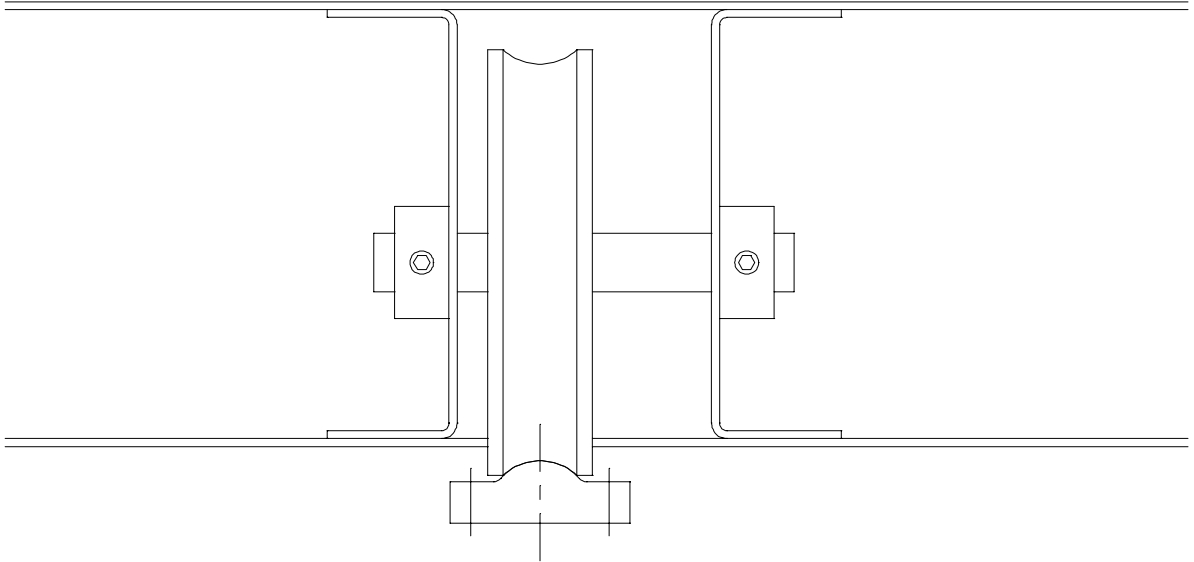

Figure 8
SECTION VIEW OF GUIDE WHEEL

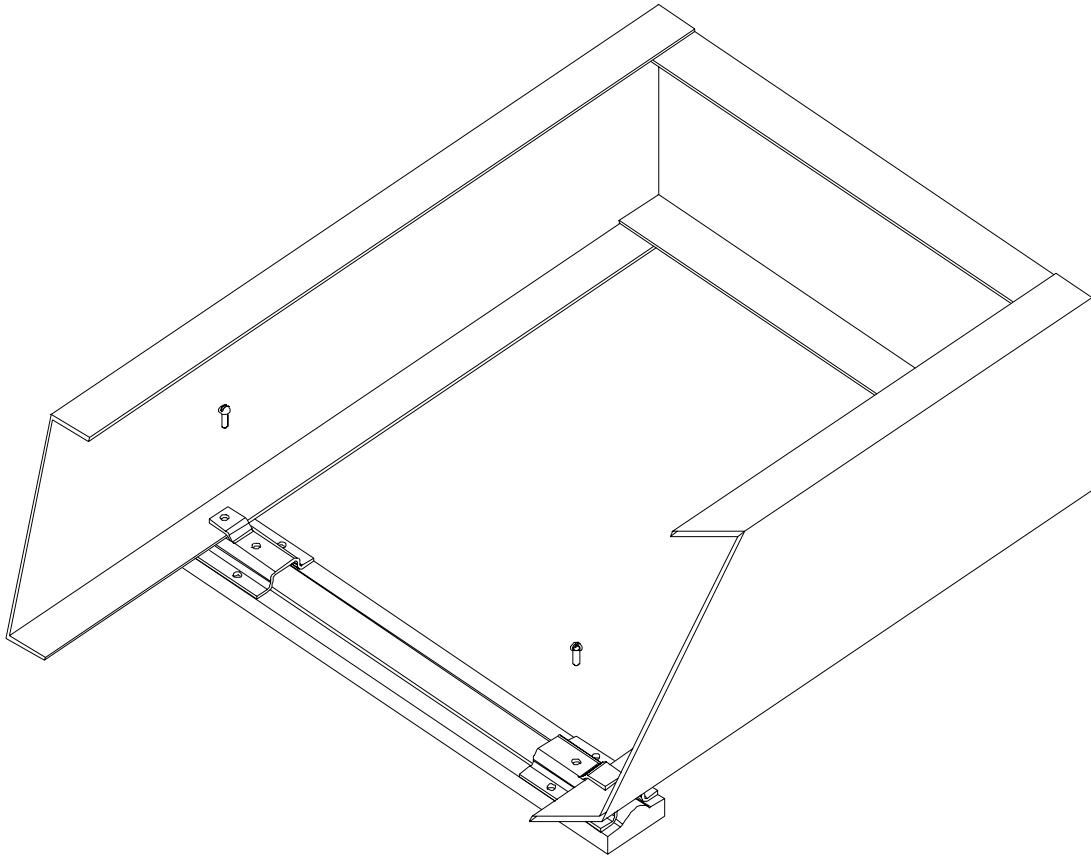

Figure 9
DETAIL VIEW OF STATIC BASE CLIP ATTACHMENT

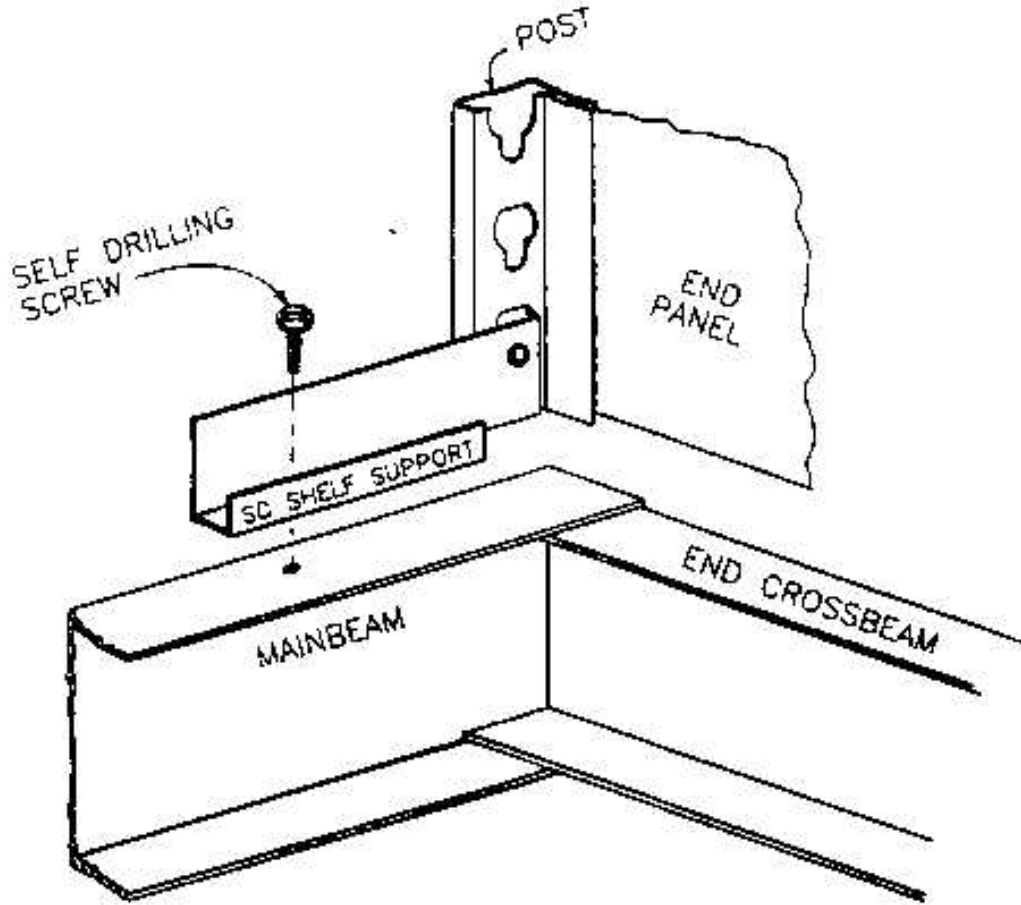

Figure 10
DETAIL VIEW OF MOUNTING OF SHELVING ON CARRIAGE

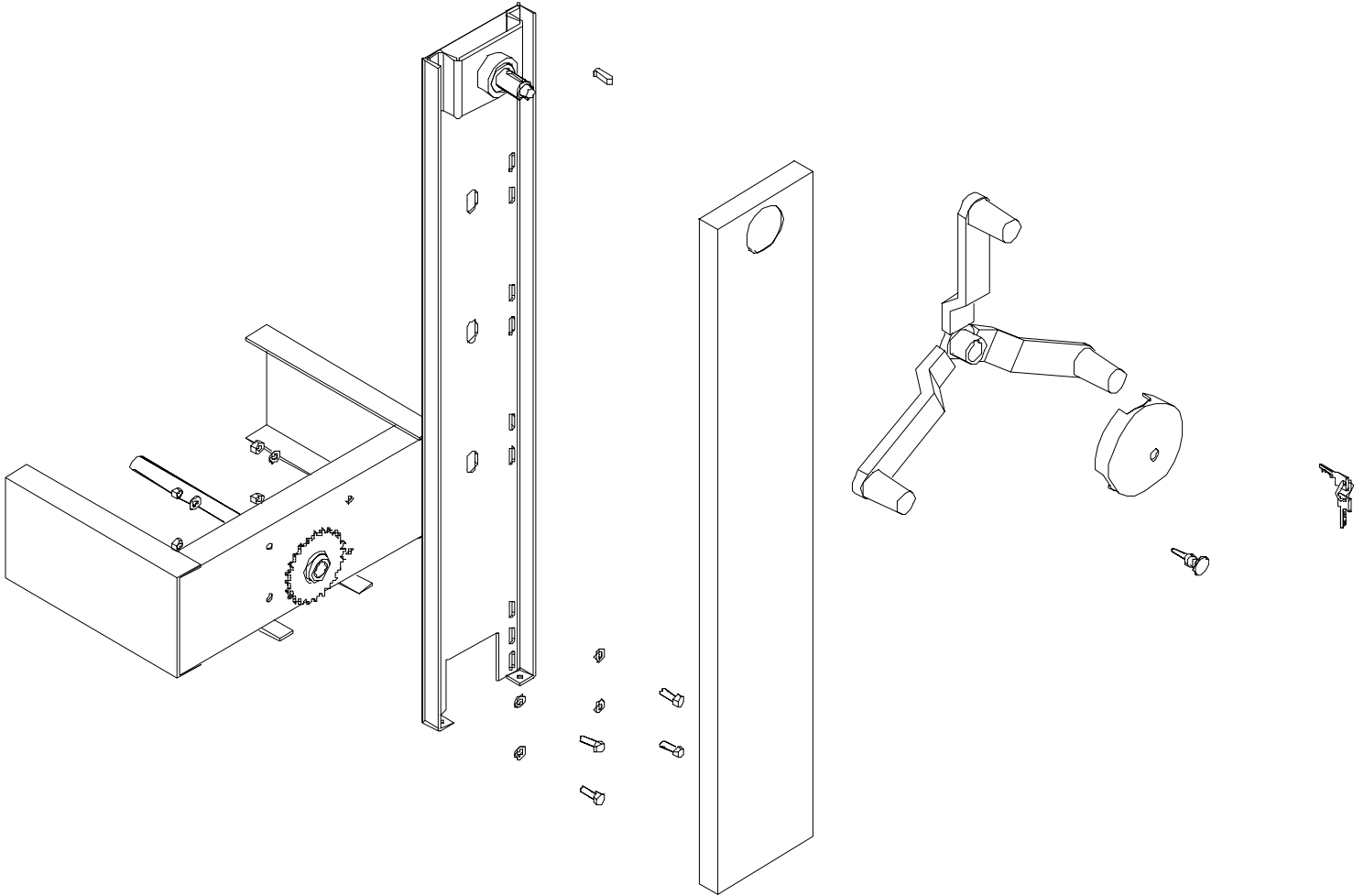

Figure 11
DETAIL VIEW OF CHAIN BOX ASSEMBLY

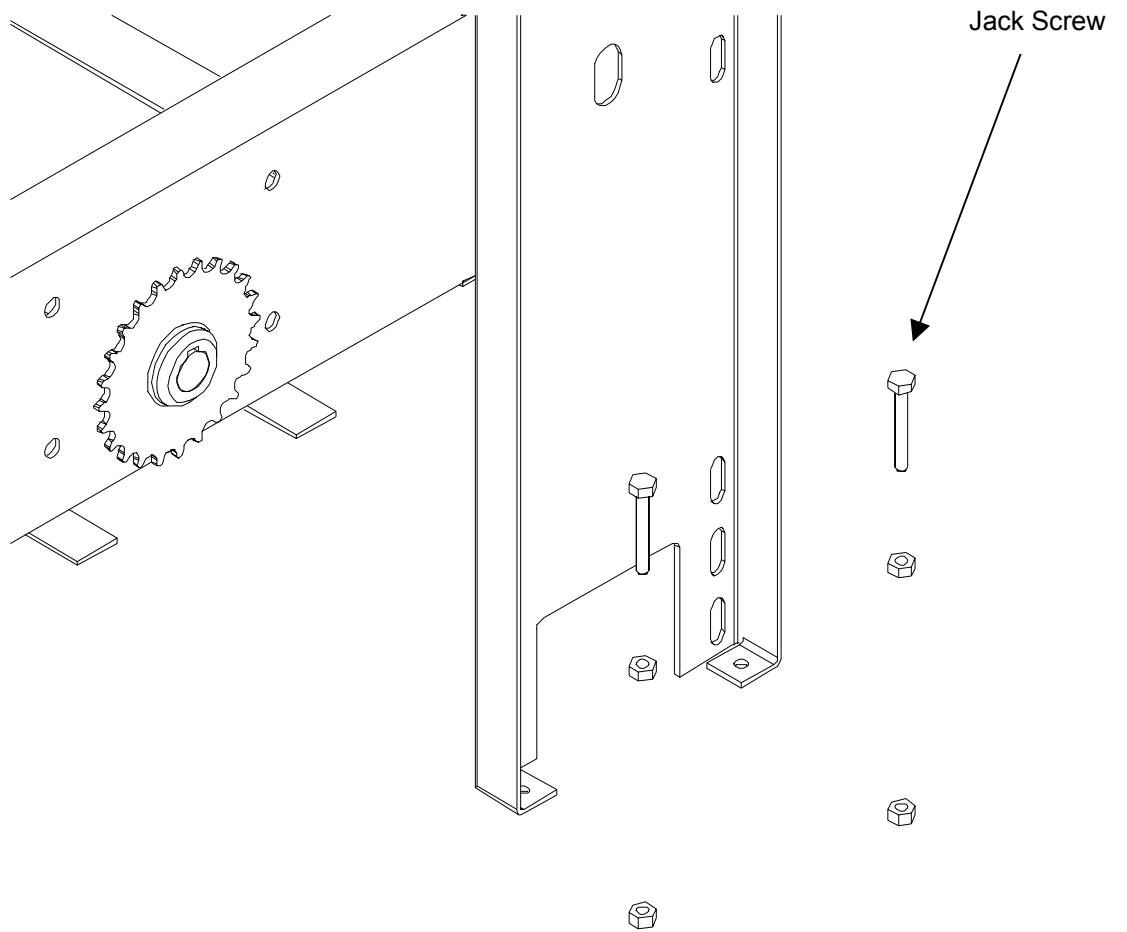

Figure 12
DETAIL VIEW OF JACK SCREWS ASSEMBLY

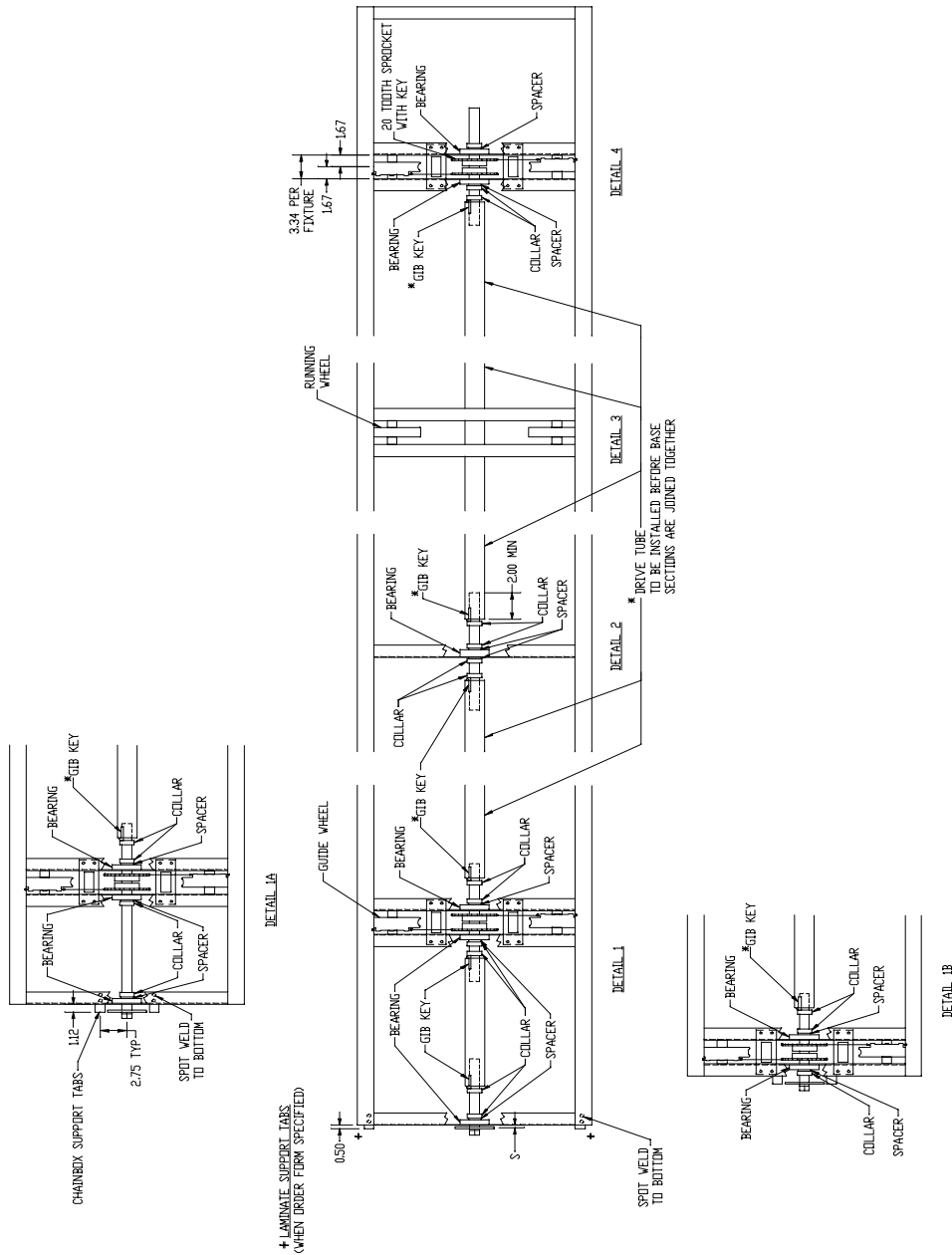

Figure 13
 DETAIL DRAWING OF SYNCHRO DRIVE SYSTEM

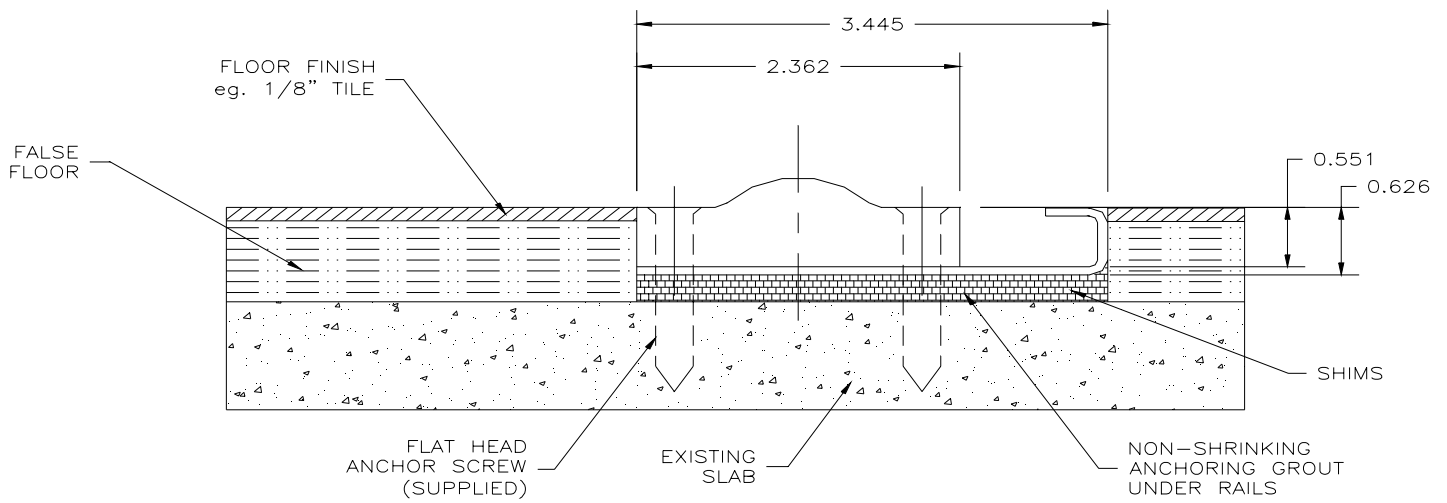

Figure 14
 SECTION VIEW THROUGH ANTI-TIP RAIL WITH FALSE FLOOR

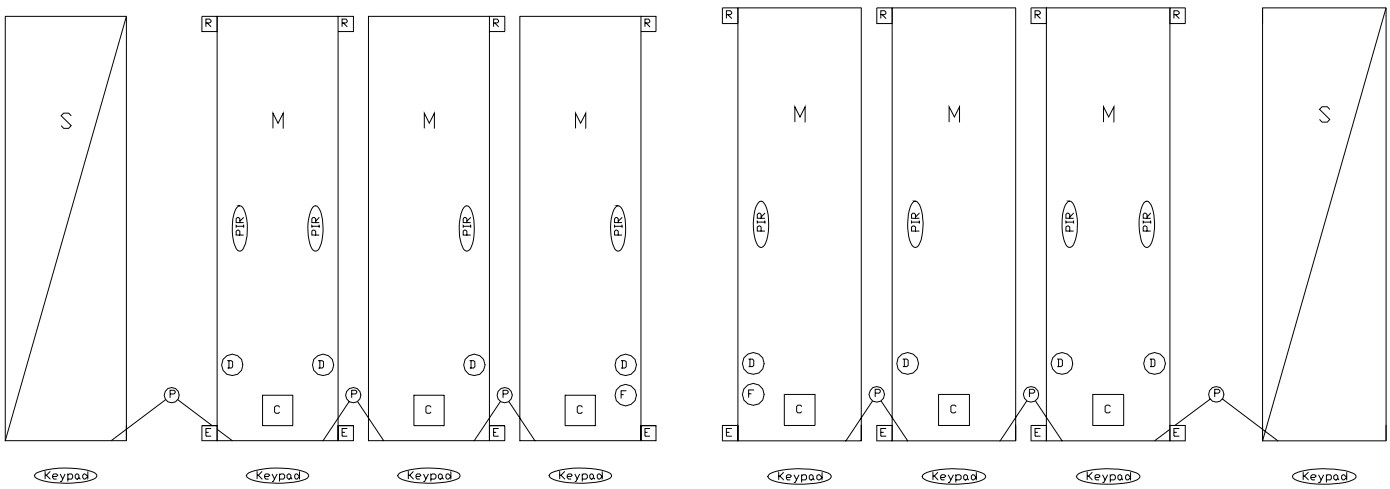

Figure 15

[1] STATIC CARRIAGE TO LEFT OR RIGHT OF MOVABLES (OPEN ENDED SYSTEM)

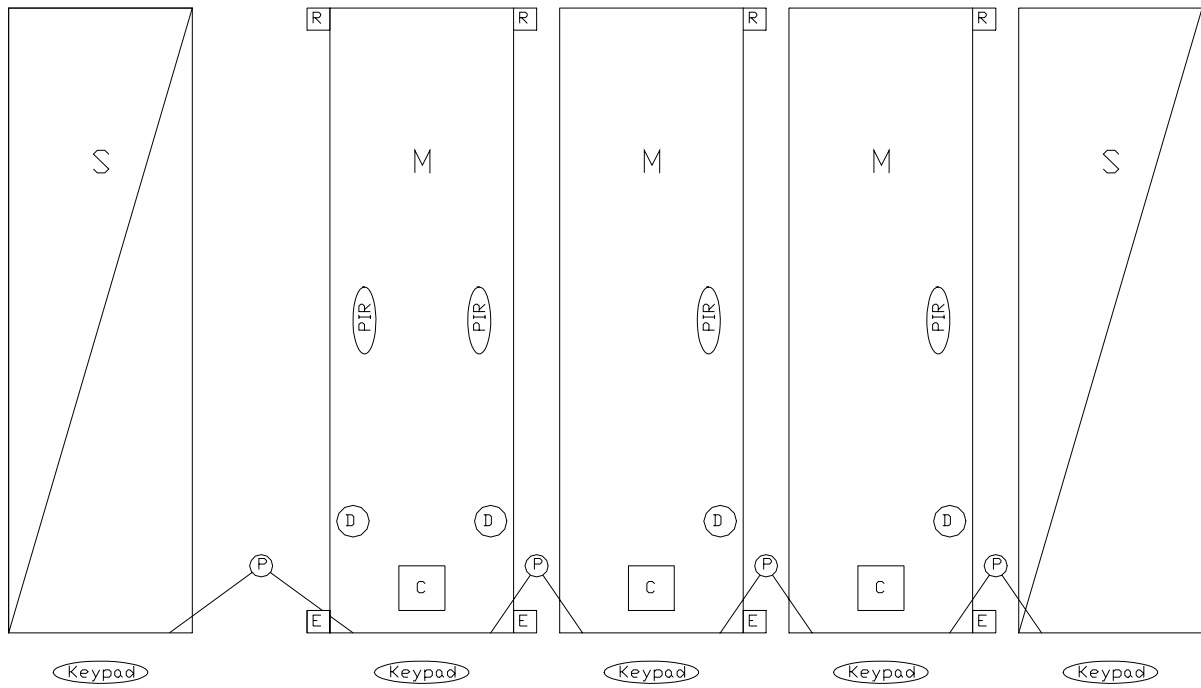

Figure 16

[2]STATIC CARRIAGES AT BOTH ENDS (CLOSED ENDED SYSTEM)

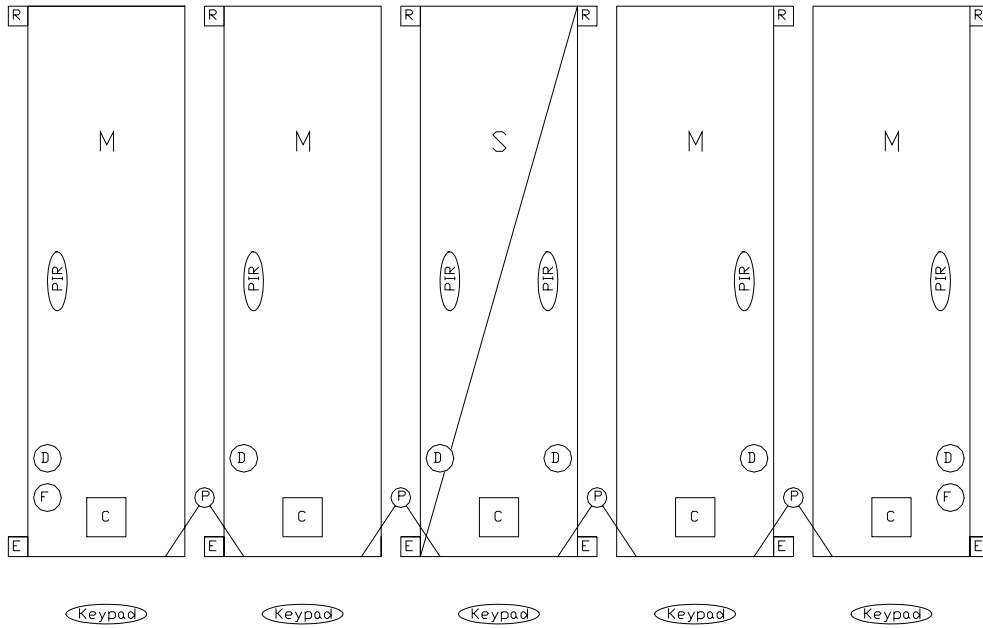

Figure 17

[1] STATIC CARRIAGE IN CENTER OF MOVABLE CARRIAGES (OPEN ENDED SYSTEM)

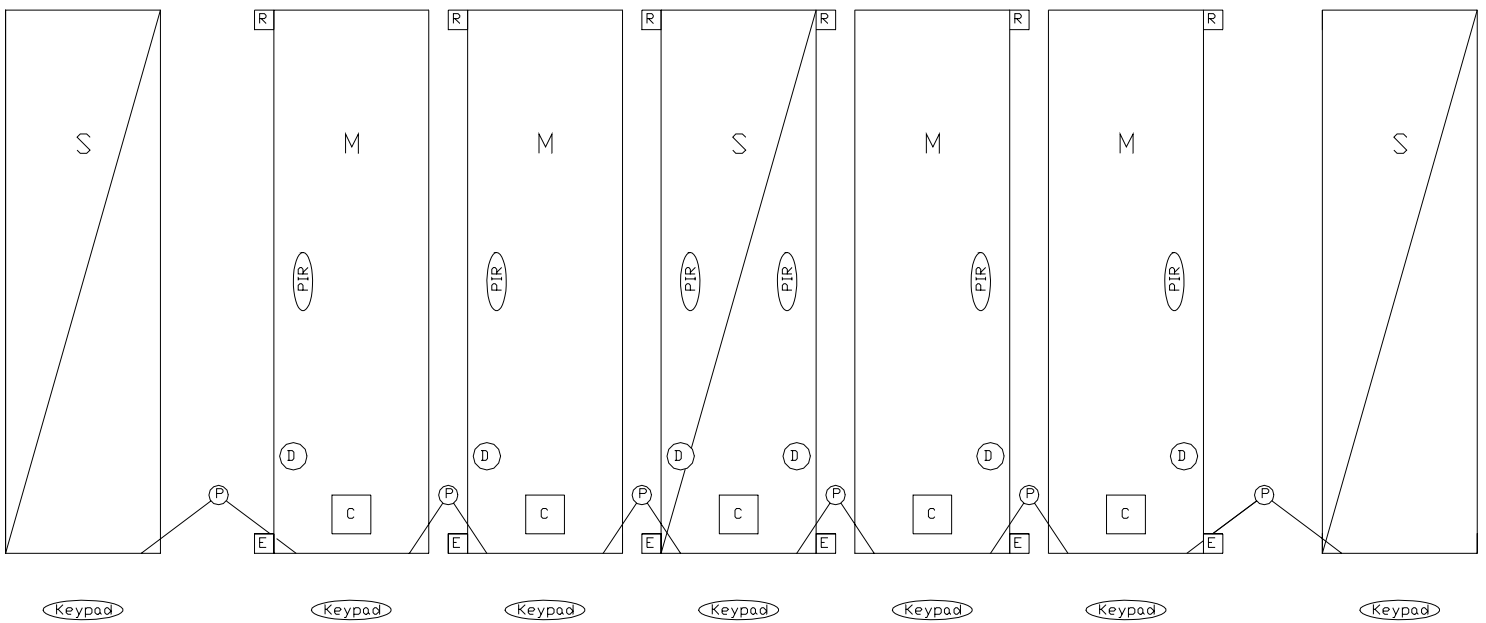

Figure 18

[1] STATIC CARRIAGE IN CENTER OF MOVABLE CARRIAGES ([2] STATIC CARRIAGES, CLOSE ENDED SYSTEM)

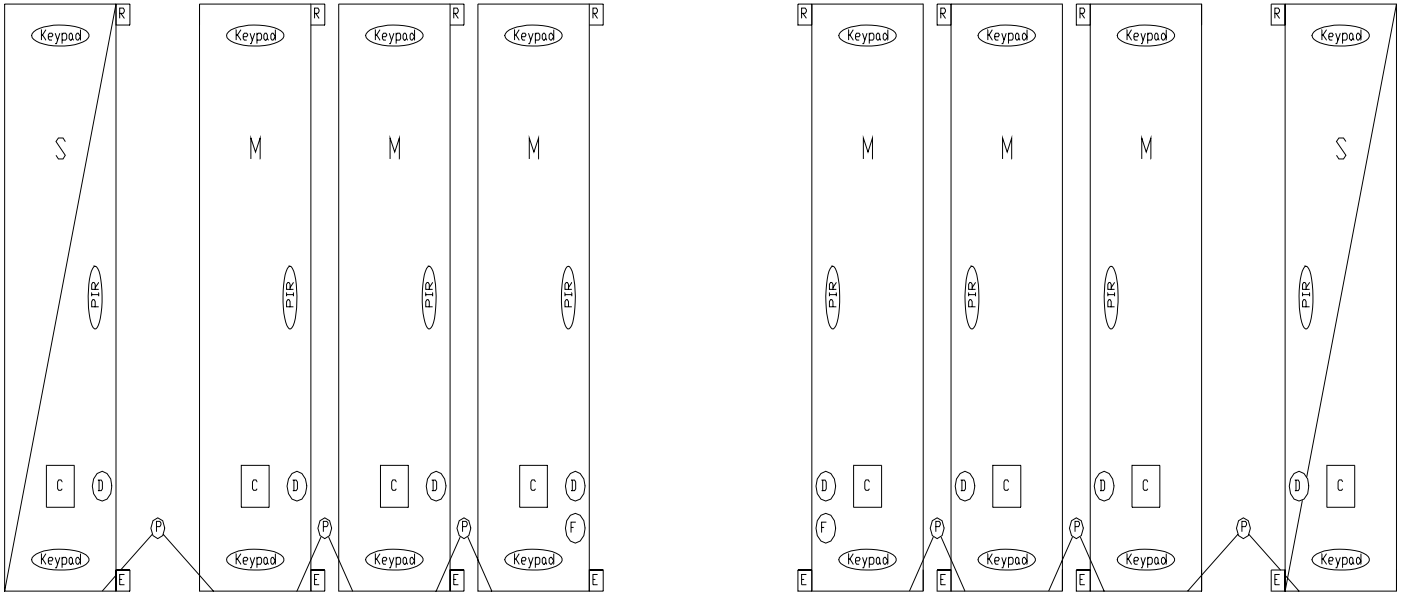

Figure 19

**DUAL ACCESS [1]STATIC CARRIAGE TO LEFT OR RIGHT OF MOVABLES
 (OPEN ENDED SYSTEM)**



Figure 20

**DUAL ACCESS [1]STATIC CARRIAGE IN CENTER OF MOVABLE CARRIAGES
 ([2]STATIC CARRIAGES, CLOSE ENDED SYSTEM)**

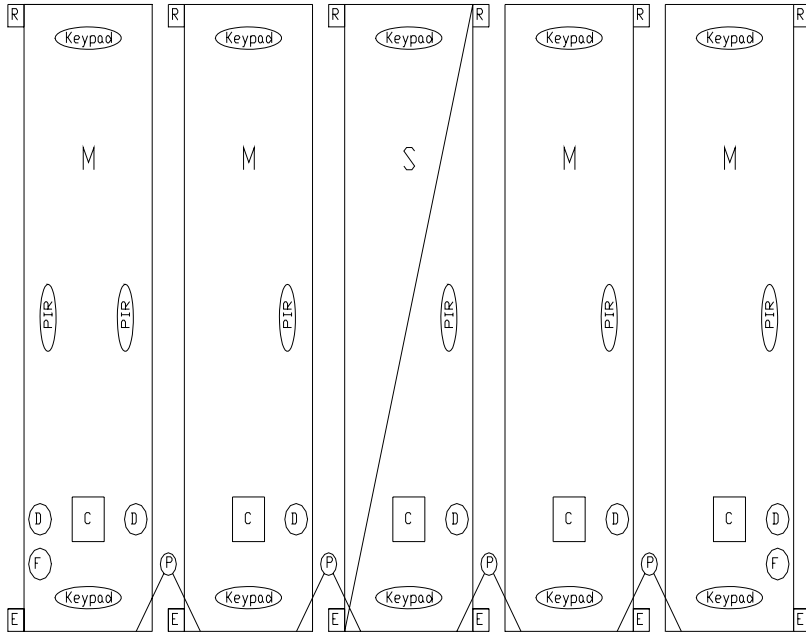

Figure 21

**DUAL ACCESS [1] STATIC CARRIAGE IN CENTER OF MOVABLE CARRIAGES
 (OPEN ENDED SYSTEM)**

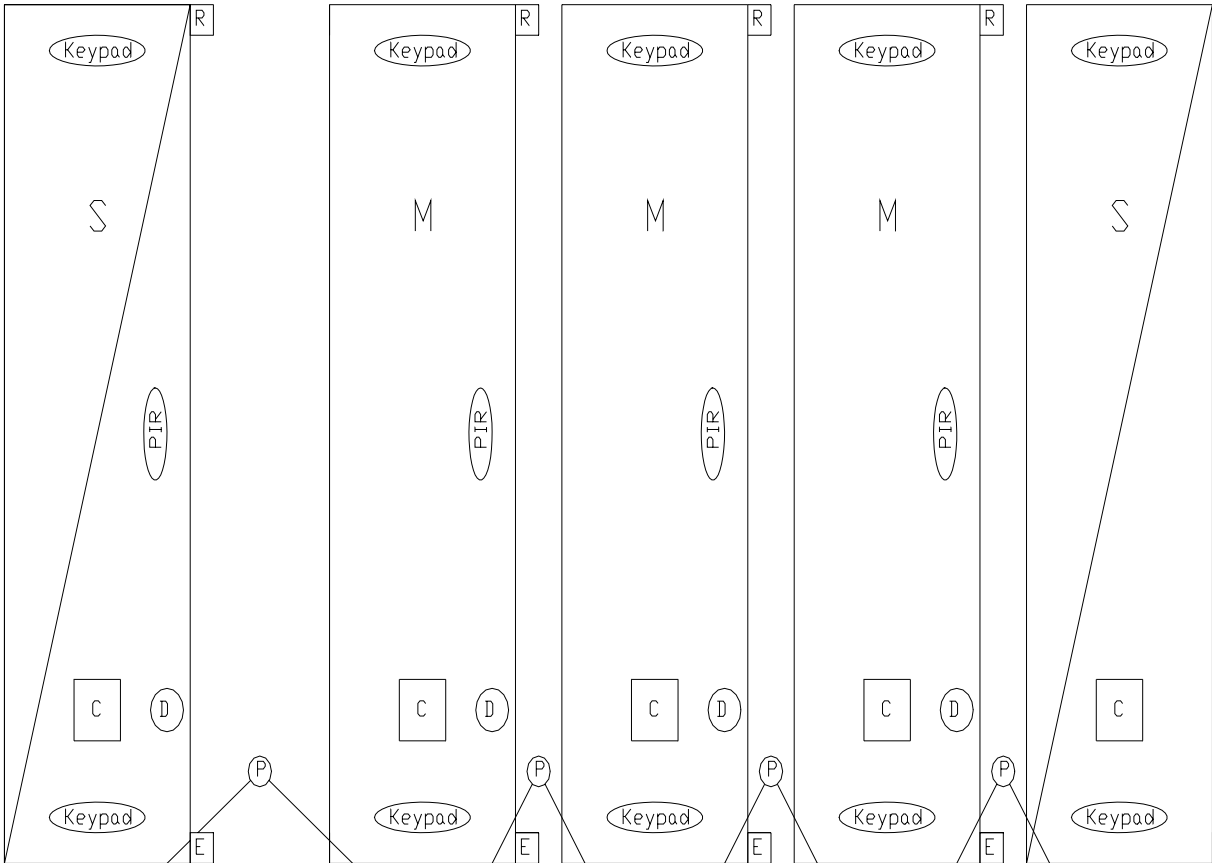

Figure 22

DUAL ACCESS [2] STATIC CARRIAGES AT BOTH ENDS (CLOSED ENDED SYSTEM)

INDEX

3	L
3" and 6" TWIN RAMP INSTALLATION, 11	LOW PROFILE (3750) INSTALLATION, 26
4	M
4" and 12" ADA RAMP INSTALLATION, 14	MECHANICAL ASSIST MOBILE BASE INSTALLATION, 26
C	MISCELLANEOUS INFORMATION, 41
CHAIN-IN –FLOOR RAIL, 18	O
D	OFFICE 1000 (3100) AND INDUSTRIAL (1500) INSTALLATION, 30
DRAWINGS, 43	P
E	P3™ MOBILE SYSTEMS, 35
ELECTRICAL MOBILE SYSTEM INSTALLATION, 35	POWERPLUS™ MOBILE SYSTEMS, 35
END STOP INSTALLATION, 17	PURPOSE OF MANUAL, 1
F	R
FALSE FLOOR INSTALLATIONS, 41	RAIL AND RAMP INSTALLATION, 6
G	RAIL INSTALLATION, 9
GENERAL GUIDELINES, 6	S
GENERAL INFORMATION, 2	SAFETY, 2
H	STATIC BASE INSTALLATION, 19
HAND-PUSH MOBILE BASE INSTALLATION, 22	STATIC BASE INSTALLATION INSTRUCTION, 19
I	SYSTEM BENEFITS, 1
INSTALLATION, 22	T
INTRODUCTION, 1	TOOLS AND MATERIALS, 4
	W
	WARRANTY, 3