

Aurora Shelving Products 12” Drawer Installation Instructions

NOTE: Shelving unit must be anchored to the floor through the Quik-Bases in front and back and must be anchored to a wall or other shelving unit in back.

1. Starting from the bottom, install shelf supports in the front and back (8) keyhole slots (12”) up from the Quik-Base. Secure the back shelf support to the posts using a Tek screw through the holes in the ears of the shelf support (see figure 1).
2. Install (4) Rivet Brackets (3) keyhole slots (5”) down from the shelf support in the posts.
3. Install slides in slide brackets by slipping lances in slides into the slots in the slide brackets. (LH slide in LH bracket, RH slide in RH bracket (see figure 2).
4. Drop the ears of the slide brackets into the top of the channel of the shelf supports and secure using #10-32 x 1/2 screws and #10 nuts. Secure slide brackets to the rivet brackets using #10 x 3/8 sheet metal screws (see figures 3 and 4). If this is your second drawer or more, install the wire interlock rod between the slides on each side (see figure 5).

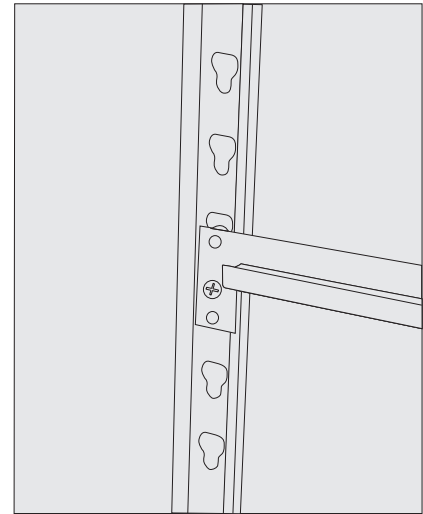

Figure 1

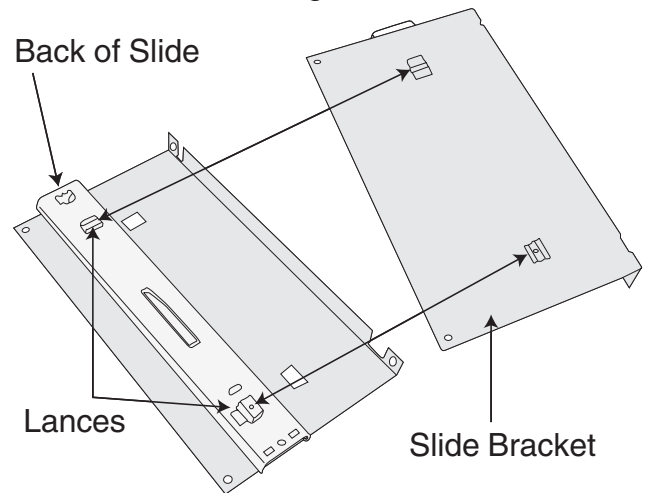

Figure 2

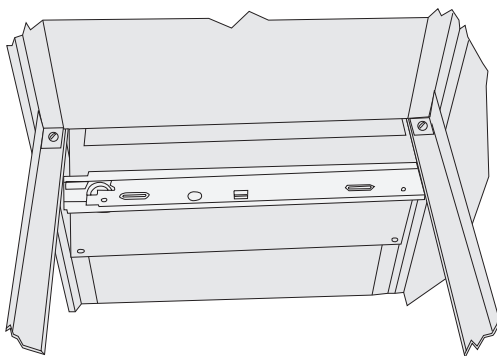

Figure 3

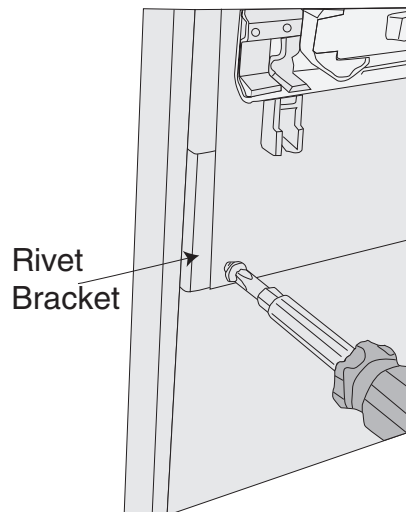

Figure 4

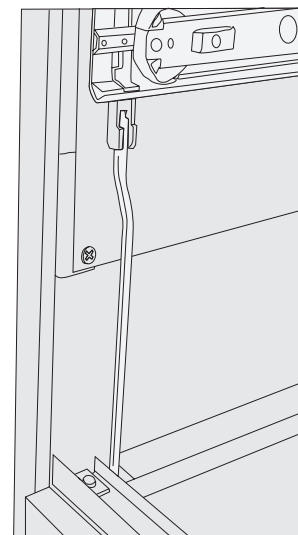

Figure 5

5. Remove the screw(s) joining the drawer front to the drawer front liner, then place the drawer body on the drawer front and liner and secure with #10 x $\frac{3}{8}$ sheet metal screws (see figure 6).
6. Fully extend slides, then drop the drawer onto the slides. Fit the lances of the drawer slide into the embossed pockets in the slide (see figure 7).
7. The drawer fronts may need to be adjusted to line up evenly.
8. Slide the hanger bars into the slots of the drawer.

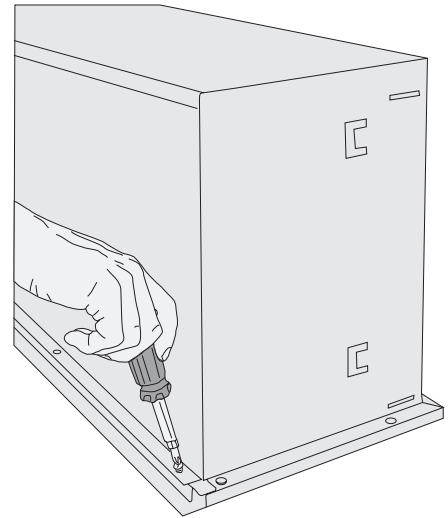

Figure 6

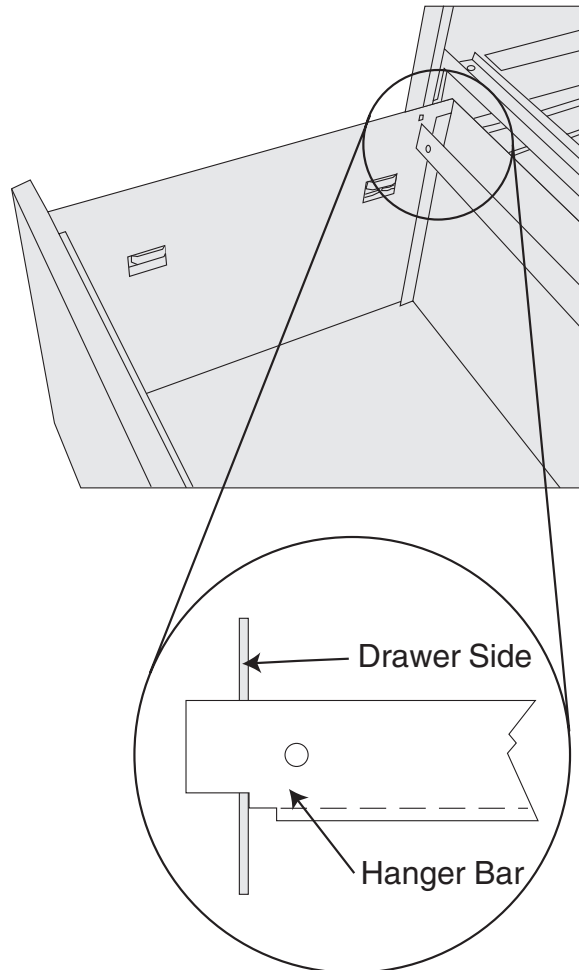

Figure 7